

# Vinyl Siding Installation Manual



Updated December 2010



VINYL SIDING INSTITUTE  
America  
Sides with  
Vinyl

This manual is published by the Vinyl Siding Institute, Inc. (VSI) as a service to the industry. VSI members are manufacturers of vinyl siding and other polymeric siding and suppliers to the industry. The information provided in this publication is offered in good faith and believed to be reliable, but is made without warranty, express or implied, as to merchantability, fitness for a particular purpose, or any other matter. VSI does not endorse the proprietary products or processes of any manufacturer.

This publication is not intended to provide specific advice, legal or otherwise, on particular products or processes. Readers should consult with their own legal and technical advisors, vinyl siding suppliers, and other appropriate sources (including but not limited to product or package labels, technical bulletins, or sales literature) that contain information about known and reasonably foreseeable health and safety risks of their proprietary products and processes. VSI, its members, and contributors do not assume any responsibility for the users' compliance with applicable laws and regulations, nor for any persons relying on the information contained in this guide.

Information about individual manufacturers' products contained herein has been provided by those manufacturers, who are solely responsible for the accuracy and completeness of the data.

### **Use of Manufacturers' Instructions**

Some specialized products may require unique installation instructions. Please contact the manufacturer directly for information about installing those products.

For general information about vinyl siding, contact the Vinyl Siding Institute at:

**VINYL SIDING INSTITUTE**



National Housing Center  
1201 15th Street NW, Suite 220  
Washington, DC 20005  
Website: [www.vinylsiding.org](http://www.vinylsiding.org)

Copyright (c) (2010) The Vinyl Siding Institute, Inc. All rights reserved. No part of this work may be reproduced or used in any form or by any means—graphic, electronic, or mechanical, including photocopying, recording, taping, or information storage and retrieval systems—without the written permission of the copyright owner, VSI. Users may download this manual to their own computers and make multiple machine-readable copies and/or print hard copies for personal use, as long as they do not alter, modify, adapt, display, publish, sell, or prepare derivative works based upon such material.

# CONTENTS

<b>Foreword</b> .....	<b>1</b>
<b>Important Notes</b> .....	<b>2</b>
Building Codes.....	2
Water-Resistive Barrier .....	2
Fire Safety Information.....	3
Residing Over Asbestos Siding.....	3
Storage and Transportation.....	3
Historic Restoration.....	4
Cleanup .....	4
Disposal .....	5
Basic Installation Rules.....	6
<b>Terms to Know</b> .....	<b>7</b>
<b>Materials, Tools, and Accessories</b> .....	<b>9</b>
Panel Profiles .....	9
Basic Installation Tools and Equipment .....	9
Special Tools.....	10
Accessories .....	10
<b>Getting Started</b> .....	<b>11</b>
Materials .....	11
How to Measure.....	11
Estimating Worksheet .....	13
Fastener Choices.....	14
Fastening Procedure .....	15
Cutting the Siding.....	16
Preparing the Walls.....	17
<b>Installing Accessories</b> .....	<b>18</b>
Outside and Inside Corner Posts.....	18
Starter Strip .....	19
Windows, Doors, and Roof Lines.....	20
Gable and Trim.....	22
<b>Horizontal Siding Installation</b> .....	<b>23</b>
Installing Panels.....	23
Fitting Siding Around Fixtures .....	24
Fitting Under Windows .....	24

# CONTENTS (CONTINUED)

Sidewall Flashing at Roof Lines.....	25
Finishing at the Top.....	26
Transition from Horizontal to Vertical.....	27
Transition from Brick to Vinyl Siding.....	27
<b>Vertical Siding and Accessories Installation .....</b>	<b>27</b>
Preparation .....	27
Accessories .....	28
Sidewalls.....	29
Gable Ends.....	31
<b>Soffit Installation.....</b>	<b>32</b>
Preparation .....	32
Installation Over Open Eaves .....	32
Installation Over Enclosed Eaves .....	35
Porch Ceilings.....	36
<b>Other Recommendations.....</b>	<b>37</b>
Attaching Shutters.....	37
Replacing a Damaged Panel .....	37
Capping a Corner Post .....	38
Repairing a Damaged Corner Post.....	38

# FOREWORD

Known for its outstanding performance, vinyl siding is increasingly the exterior cladding of choice for homeowners, remodeling contractors, architects, and builders. Compared to other siding products, vinyl is attractive, durable, easy to maintain, and cost-effective. Vinyl siding is available in a variety of architectural styles, eye-catching colors, design-enhancing profiles, finishes, and textures.

For best results, it is recommended that vinyl siding meet the requirements of the *ASTM D3679–Standard Specification for Rigid Poly(VinylChloride) (PVC) Siding* from ASTM International. As a service to the industry, the Vinyl Siding Institute (VSI) sponsors a program that allows manufacturers to certify, with independent, third-party verification, that their siding meets or exceeds this specification. For a listing of certified products, see VSI’s website at [www.vinylsiding.org](http://www.vinylsiding.org). In addition, look for the certification label on boxes of siding (Fig. 1).



Figure 1

This manual sets forth the basic guidelines for vinyl siding installation. The instructions herein are based, in part, on *ASTM D4756, Standard Practice for Installation of Rigid Poly(VinylChloride) (PVC) Siding and Soffit*, the standard method for installation of vinyl siding and soffit. Updated information has been added as necessary. **Additionally, it is recommended that installers review local building codes and manufacturers’ literature for variations that may apply to specific products and/or geographic areas.**

The method of applying vinyl siding and soffit is essentially the same for new construction and residing. However, where required, special instructions for new construction and residing are included, as well as recommendations for historic restoration projects. In all applications, care should be exercised to properly prepare the structure. See the “Basic Installation Rules” and additional details throughout this document for proper installation techniques.

NOTE: Vinyl siding installers with at least one year of experience can become VSI Certified Installers, if they successfully complete a course and pass a written examination. Certified Installers receive an identification badge and are listed on VSI’s website. For more information on the VSI Certified Installer Program, visit [www.vinylsiding.org](http://www.vinylsiding.org).



# IMPORTANT NOTES

## Building Codes

Installers need to be aware of building code requirements in the geographic areas where they are installing, and how the codes relate to the instructions given in this manual and by the siding manufacturer. The requirements of local building codes must always be observed, because they represent the legal requirements for an installation in a given jurisdiction. However, most local codes are based on the national model building codes. Model codes themselves do not have the force of law until they are adopted by a state or local jurisdiction. In the United States, the primary source of model codes is the International Code Council, which publishes the International Building Code (IBC) and International Residential Code (IRC). In Canada, the primary model code is the National Building Code (NBC), published by the National Research Council of Canada.

Most of the model building codes, and thus the local codes based on them, recognize that the manufacturer of a product usually has a good idea of how its product should be installed in order to provide best performance. Therefore, most codes reference the manufacturer's instructions and state that the product must be installed according to the code and the manufacturer's instructions. However, any specific requirement in a local code will usually override any provision of the manufacturer's instructions, especially if the local requirement is more restrictive. Therefore, vinyl siding installations must always conform to local building codes, but the local code may also require that the installation conform to the siding manufacturer's instructions.

The codes provide the greatest recognition to products that have been certified to a recognized standard by an independent third party. In fact, editions of the IBC and IRC model codes since 2006 require that vinyl siding be certified to *ASTM D3679* by a third-party agency. As these editions of the model codes become adopted by local jurisdictions, you can expect that code officials will want to verify that the siding is properly certified (which can usually be determined by identifying the VSI certified product label on the box—see page 1) and that the installation conforms to the manufacturer's instructions. You should always make sure that the instructions are available on the job site for an inspector to review.

This manual is not a code and it is not a substitute for the manufacturer's instructions. However, it has been developed by referencing the provisions of the model building codes, the requirements of *ASTM D4756*, and generally accepted installation practices within the vinyl siding industry. This manual therefore reflects the most common installation requirements that apply to the vast majority of vinyl siding products. Use this manual to understand how vinyl siding and soffit should generally be installed, but be prepared to comply with any different provisions of local codes and the manufacturer's instructions for a specific product.

## Water-Resistive Barrier

***Vinyl siding has always been designed as an exterior cladding, not a water-resistive barrier. Vinyl siding is designed to allow the material underneath it to breathe; therefore, it is not a watertight covering.*** Because of its design and application, it provides a supplemental rain screen that enhances the water-resistive barrier system by reducing the amount of water that reaches the underlying water-resistive barrier.

**What Is a Water-Resistive Barrier System?** It is a system that includes water shedding materials and water diversion materials. Water-resistive barrier systems commonly consist of a combination

of exterior cladding, flashed wall openings and penetrations, water-resistive barrier material, and sheathing. Effective water-resistive barrier systems will shed the water initially, control moisture flow by capillary and diffusion action, and minimize absorption into the wall structure. The level of water resistance required is determined by the applicable building code and structure.

**Best Practice:** To achieve designed performance, vinyl siding must be installed over a water-resistive barrier system that includes 1) a continuous water-resistive material and 2) properly integrated flashing around all penetrations and where vinyl siding interfaces with other building products such as brick, stone, or stucco. Refer to the manufacturer's instructions for specific product applications and recommendations. Whichever product(s) you decide to use as part of a water-resistive barrier system, be certain the materials meet the applicable building code by contacting the manufacturer of the water-resistive barrier material(s). Always consult the applicable building code for minimum water-resistive barrier requirements in your area. Keep in mind that additional measures may provide better protection against water intrusion than the minimum requirements of the building code.

## Fire Safety Information

Exterior vinyl building materials require little maintenance for many years. Nevertheless, common sense dictates that builders and suppliers of vinyl products store, handle, and install vinyl materials in a manner that avoids damage to the product and/or the structure. Owners and installers should take a few simple steps to protect vinyl building materials from fire.

**To Home and Building Owners:** Rigid vinyl siding is made from organic materials and will melt or burn when exposed to a significant source of flame or heat. Building owners, occupants, and outside maintenance personnel should always take normal precautions to keep sources of fire, such as grills, and combustible materials, such as dry leaves, mulch, and trash, away from vinyl siding.

**To the Building Trades, Specifiers, Professionals, and to Do-It-Yourself Installers:** When rigid vinyl siding is exposed to significant heat or flame, the vinyl will soften, sag, melt, or burn, and may thereby expose material underneath. Care must be exercised when selecting underlayment materials because many underlayment materials are made from organic materials that are combustible. It is important to ascertain the fire properties of underlayment materials prior to installation. **All building materials should be installed in accordance with local, state, and federal building code and fire regulations.**

## Residing Over Asbestos Siding

Asbestos siding is a regulated material, and the appropriate environmental agency or local building code official should be contacted before residing over this product.

## Storage and Transportation

When transporting vinyl siding to a job site, make certain to keep the cartons flat and supported along their entire length. At the job site, take the following precautions when storing vinyl siding:

- Store the cartons on a flat surface and support the entire length of the cartons.
- Keep the cartons dry.
- Store the cartons away from areas where falling objects or other construction activity may cause damage.

- Do not store the cartons in stacks more than six boxes high, and make sure the stacks are stable.
- Do not store the cartons in any location where temperatures may exceed 130° F/54.4° C (e.g., on blacktop pavement during unusually hot weather or under dark tarps or plastic wraps without air circulation).

## Historic Restoration

When using vinyl siding for historic restoration projects, VSI recommends the following:

- If a building is in a historic area, local historic district, or has been designated as a historic building, make sure that approval for the use of vinyl siding has been obtained from the local historic society or local Historic District Commission. This applies to building additions as well.
- Before a historic building is resided, it should be examined for moisture, insect infestation, structural defects, and other problems that may be present. These problems should be addressed and the building pronounced “healthy” before residing with any material.
- Do not damage or remove the original siding. If at all possible, do not alter the original structure, so that the application of vinyl siding is reversible (i.e., the original siding would remain intact in the future, so that if desired, the vinyl siding could be removed). Exception: “In cases where a nonhistoric artificial siding has been applied to the building, the removal of such a siding before application of vinyl siding would, in most cases, be acceptable.” (Preservation Briefs, Number 8, U.S. Department of Interior, 1984.)<sup>1</sup>
- Exercise every care to retain architectural details wherever possible. Do not remove, cover, or add details until the building owners’ written approval has been obtained. Determine that the owner has consulted the local historic society for approval.
- Use siding that closely approximates the appearance of the original siding in color, size, and style. In historic districts, the goal is to match the product as closely as possible and retain the original trim.

## Cleanup

The beauty of vinyl siding is maintained with little effort. Although vinyl siding will get dirty, like anything exposed to the atmosphere, a heavy rain will do wonders in cleaning it. Or, it’s possible to wash it down with an ordinary garden hose. If neither rain nor hosing does a satisfactory job, follow these simple instructions:

1. Use an ordinary, long-handled car washing brush. This brush has soft bristles, and the handle fastens onto the end of the hose. It allows the siding to be washed just like a car. Avoid using stiff bristle brushes or abrasive cleaners, which may change the gloss of the cleaned area and cause the siding to look splotchy.
2. To remove soot and grime found in industrial areas, wipe down the siding with a solution made up of the following:
  - 1/3 (0.08 liter) cup powder detergent (e.g., Fab<sup>®</sup>, Tide<sup>®</sup>, or equivalent powder detergent)\*
  - 2/3 cup (0.16 liter) powder household cleaner (e.g., Soilax<sup>®</sup>, Spic & Span<sup>®</sup>, or equivalent)\*
  - 1 gallon (3.8 liters) water

<sup>1</sup> Preservation Briefs, Number 8, can be ordered by contacting the Superintendent of Documents at 202/512-1800. Or, the brief can be viewed via the Heritage Preservation Web site at [www2.cr.nps.gov](http://www2.cr.nps.gov). GPO stock number: 024-005-01026-2

3. If mildew is a problem, use the solution previously mentioned, but add 1 quart (0.95 liter) liquid laundry bleach.
4. When washing down the entire house, start at the bottom and work up to the top in order to prevent streaking.
5. For stubborn stains, use the following chart:

<b>STAIN</b>	<b>CLEANERS*</b>
Bubble Gum	Fantastik <sup>®</sup> , Murphy's Oil Soap <sup>®</sup> , or solution of vinegar (30 percent) and water (70 percent)
Crayon	Lestoil <sup>®</sup>
DAP (Oil-based caulk)	Fantastik <sup>®</sup>
Felt-tip Pen	Fantastik <sup>®</sup> or water-based cleaners
Grass	Fantastik <sup>®</sup> , Lysol <sup>®</sup> , Murphy's Oil Soap <sup>®</sup> , or Windex <sup>®</sup>
Lipstick	Fantastik <sup>®</sup> or Murphy's Oil Soap <sup>®</sup>
Lithium Grease	Fantastik <sup>®</sup> , Lestoil <sup>®</sup> , Murphy's Oil Soap <sup>®</sup> , or Windex <sup>®</sup>
Mold and Mildew	Fantastik <sup>®</sup> or solution of vinegar (30 percent) and water (70 percent)
Motor Oil	Fantastik <sup>®</sup> , Lysol <sup>®</sup> , Murphy's Oil Soap <sup>®</sup> , or Windex <sup>®</sup>
Oil	Soft Scrub <sup>®</sup>
Paint	Brillo <sup>®</sup> Pad or Soft Scrub <sup>®</sup>
Pencil	Soft Scrub <sup>®</sup>
Rust	Fantastik <sup>®</sup> , Murphy's Oil Soap <sup>®</sup> , or Windex <sup>®</sup>
Tar	Soft Scrub <sup>®</sup>
Top Soil	Fantastik <sup>®</sup> , Lestoil <sup>®</sup> , or Murphy's Oil Soap <sup>®</sup>

\*Cleaning materials are listed in alphabetical order.

VSI does not endorse proprietary products or processes and makes no warranties for the products referenced herein. Reference to proprietary names is for illustrative purposes only and is not intended to imply that there are not equally effective alternatives.

Follow the precautionary labeling instructions on the cleaning agent container. Protect shrubs from direct contact with cleaning agents.

## **Disposal**

Dispose of all scrap or excess trim in a manner that is consistent with local and state rules and regulations. For information on recycling leftover vinyl siding scrap, visit the American Chemistry Council's website at [www.americanchemistry.com/s\\_plastics](http://www.americanchemistry.com/s_plastics) and search for "vinyl siding recycling."

## BASIC INSTALLATION RULES

Before getting started, it is important to review several rules of thumb for vinyl siding application. The following rules, which come up throughout this guide, are critical for proper vinyl siding installation:

1. Installed panels and accessories must move freely from side to side.
2. When installing a siding panel, push up from the bottom until the lock is fully engaged with the piece below it. Without stretching the panel, reach up and fasten it into place.
3. Fasten nails or other fasteners in the center of the nailing slot and make sure the fastener penetrates a minimum of 3/4" (19mm) into a nailable surface.
4. Do not force the panels up or down when fastening in position.
5. Do not drive the head of the fastener tightly against the siding nail hem. Allow approximately 1/32" (0.8mm) (about the thickness of a dime) clearance between the fastener head and the siding panel. Make sure the panels can move freely back and forth. Drive fasteners straight and level to prevent distortion and buckling of the panel.
6. Leave a minimum of 1/4" (6.4mm) clearance at all openings and stops to allow for normal expansion and contraction. When installing in temperatures below 40° F/4.4° C, increase minimum clearance to 3/8" (9.5mm).
7. Do not caulk the panels where they meet the receiver of inside corners, outside corners, or J-trim. Do not caulk the overlap joints.
8. Do not face-nail or staple through siding. Vinyl siding expands and contracts with outside temperature changes. Face-nailing can result in ripples in the siding.
9. In residing, furring or removal of uneven original siding may be necessary; take appropriate actions to ensure a smooth and continuous surface.
10. In new construction, avoid the use of green lumber as the underlayment. Keep in mind that siding can only be as straight and stable as what lies under it.
11. The installation of specific products may differ in details from the instructions given in this manual. Always follow the manufacturer's instructions, using parts specified by the manufacturer, to ensure proper installation.

# TERMS TO KNOW

**Backerboard**—a flat material used on the face of the house, applied between the studs and the siding (or over existing wall surface), to provide an even surface for installing vinyl siding.

**Buttlock**—the bottom edge of a siding or soffit panel, or accessory piece, opposite the nailing slots, which locks onto to the preceding panel.

**Channel**—the area of the accessory trim or corner post where siding or soffit panels are inserted. Channels also refer to the trim itself, and are named for the letters of the alphabet they resemble (e.g., J-channel or J-trim, F-channel, etc.).

**Course**—a row of panels, one panel wide, running the length of the house from one side to the other, or, in the case of vertical siding, from top to bottom.

**Drip Cap/Head Flashing**—an accessory installed with vertical siding to ensure that water drips away from panels and does not infiltrate them.

**Double Channel Lineal**—a siding accessory that joins two soffit panels.

**Face**—refers to the side of a siding or soffit panel that is showing once the panel has been installed.

**Face-nailing**—the action of fastening directly onto the “face” side of a panel (instead of using the nail hem slot). This practice is generally not used in siding installation.

**Fascia**—the trim covering the ends of roof rafters. **Fascia Board**—a board attached to the ends of the rafters between the roofing material and the soffit overhang. **Fascia Cap or Cover**—the covering around a fascia board.

**Flashing**—a thin, flat material that meets the requirements of ICC AC148, positioned under or behind J-channels, corner posts, windows, etc., to keep draining water from penetrating the home.

**Furring/Furring Strip**—usually a wood 1” x 2” (25.4mm x 50.8mm) strip used to even a surface in preparation for installing vinyl siding. To “fur” a surface means to apply these strips.

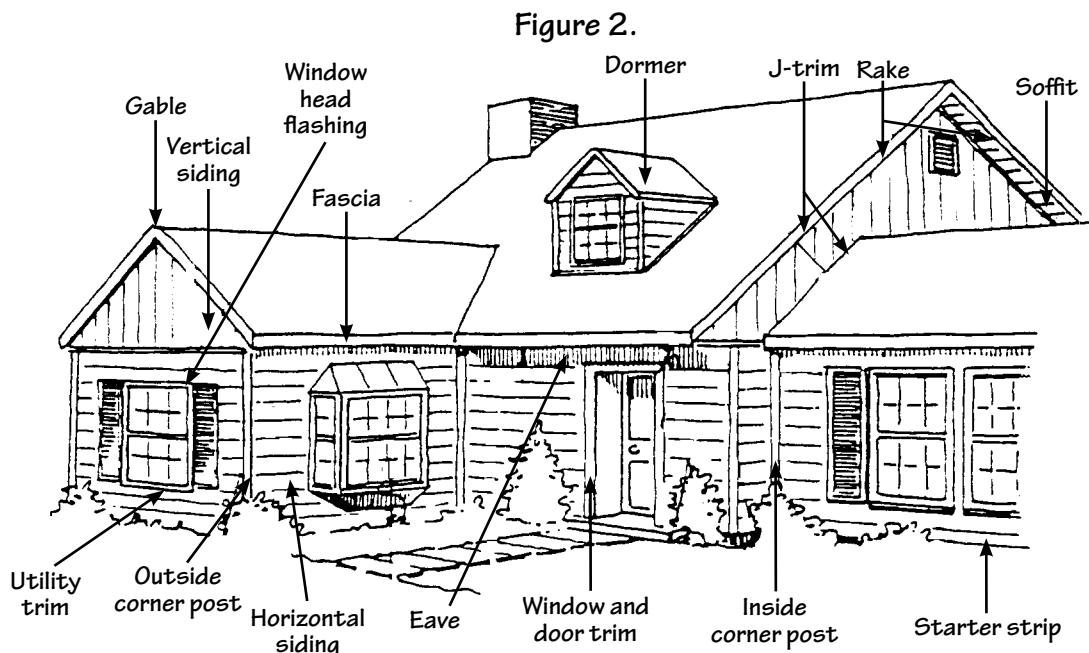

**Lap**—to overlap the ends of two siding panels or accessory pieces to allow for expansion and contraction of the vinyl product.

**Lug/Crimp**—the raised “ears” or tabs on a siding panel, created by a snap lock punch, which can be used to lock a siding panel into place when the nailing hem has been removed.

**Miter**—to make a diagonal cut, beveled to a specific angle (usually 45°). Sometimes miter cuts are made into an overlapping siding or soffit panel surface, to provide a neater appearance.

**Nail Hem (or Flange)**—the section of siding or accessories where the nailing slots are located.

**Nailing Strip**—an additional framing member installed to facilitate soffit installation.

**Nail Hole Slot Punch**—refer to page 10 for illustration and use.

**Plumb**—a position or measurement that is truly and exactly vertical, 90° from a level surface.

**Rake (roof)**—the inclined, usually projecting edge of a sloping roof.

**Rake (wall)**—the board or molding placed along the sloping sides of a gable to cover the ends of the siding.

**Scoring**—running a utility knife blade, sharpened awl, scoring tool, or other sharp implement across a soffit or siding panel face without cutting all the way through the panel. This weakens the vinyl surface in a specific area and allows the panel to be bent and broken off cleanly.

**Sealant**—any of a variety of compounds used to fill or seal joints in wood, metal, masonry, vinyl, and other materials.

**Shim**—a building material used to even a surface prior to installing vinyl siding.

**Snap Lock Punch**—refer to page 10 for illustration and use.

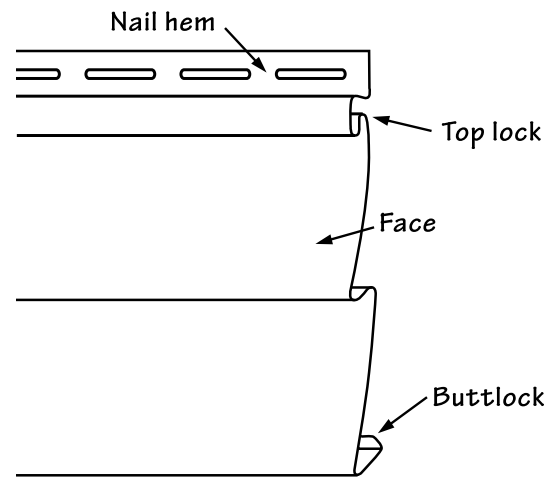

Figure 3.

**Soffit**—material used to enclose the horizontal underside of an eave, cornice, or overhang. Soffit is designed to be installed lengthwise from wall to fascia.

**Starter Strip**—an accessory applied directly to the surface of the building and used to secure the first course of siding to the home.

**Underlayment**—water-resistive material placed under vinyl siding panels.

**Utility Trim**—a piece of trim used any time the top lock has been removed from the siding, to secure a siding panel. Also referred to as “undersill” or “finish” trim.

**Water-Resistive Barrier**—a material applied between the sheathing and the siding that is intended to resist any water that penetrates through the siding and meets the requirements of ICC AC38.

**Weep Holes**—openings cut into siding or accessories to allow for water runoff.

**Zip Lock Tool**—also known as an unlocking tool; refer to page 10 for illustration and use.

# MATERIALS, TOOLS, AND ACCESSORIES

## Panel Profiles

Vinyl siding comes in a variety of shapes, textures, and colors, creating a wide array of looks for different houses. It is manufactured primarily with durable polyvinyl chloride in several different profiles, including single, double, triple, vertical, and Dutch lap (Fig. 4).

There are also various types of vinyl soffit (the material used to enclose the underside of an eave or overhang). Soffit can be vented, solid, or a combination of the two (Fig. 5) and is designed to maximize airflow, preventing moisture accumulation and heat buildup between the siding and the house.

## Basic Installation Tools and Equipment

Common hand tools, such as a hammer, fine-tooth saw, square, chalkline, level, and tape measure, are needed for proper installation (Fig. 6). Safety glasses are recommended for eye protection. Other basic tools include:

### Power Saw

A bench or radial-arm power saw can speed the cutting of the siding or soffit. A fine-tooth plywood blade (12 to 16 teeth per inch) should be used with the blade installed in the reverse direction. Some applicators prefer a hand-held power saw. In extremely cold weather, move the saw through the material slowly to prevent chipping or cracking (Fig. 7).

**NOTE:** A saw blade set up in reverse direction should be used only for cutting vinyl. Do not attempt to use it on other materials such as wood, plywood, etc.

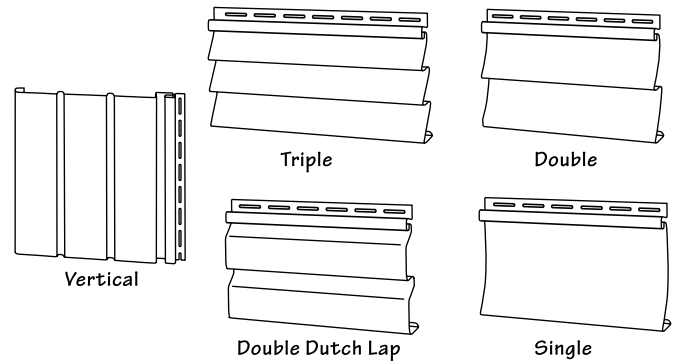

Figure 4.

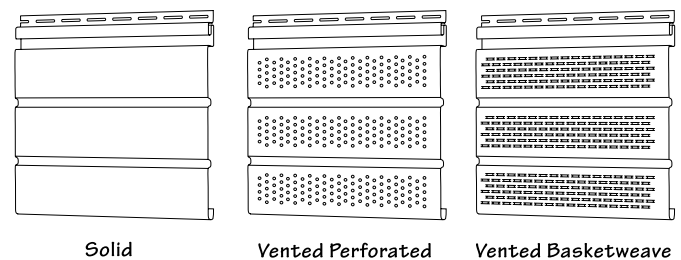

Figure 5.

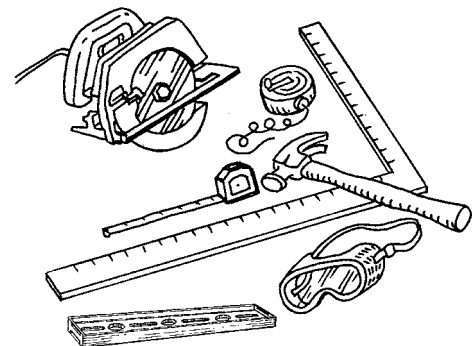

Figure 6.

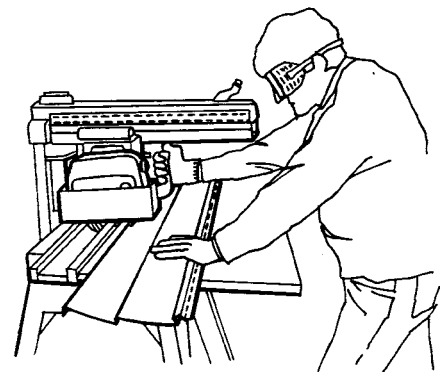

Figure 7.

## Utility Knife

Vinyl is easy to cut, trim, and score with a utility knife or scoring tool (Fig. 8).

## Tin Snips

Good quality tin snips or compound aviation-type snips will speed the cutting and shaping of the vinyl (Fig. 8).

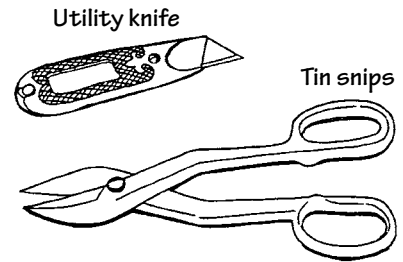
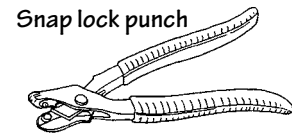

Figure 8.

## Special Tools

### Snap Lock Punch

A snap lock punch is used to punch lugs in the cut edges of siding to be used for the top or finishing course at the top of a wall, or underneath a window (Fig. 9).



### Nail Hole Slot Punch

Occasionally, it may be necessary to elongate a nail hem slot. The hole is elongated to allow for expansion and contraction (Fig. 9).

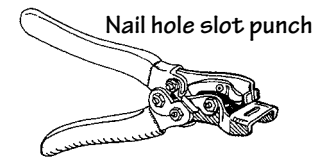

### Zip Lock (Unlocking) Tool

Remove or replace a siding panel with the unlocking tool. Insert the curved end of the tool under the end of the panel and hook onto the back lip of the buttlock. To disengage the lock, pull down and slide the tool along the length of the panel. Use the same procedure to relock a panel (Fig. 9).

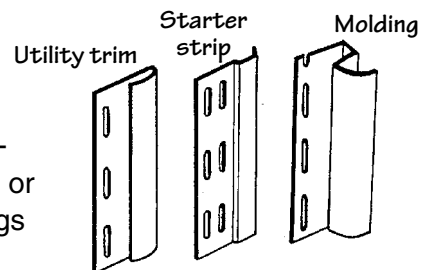

Figure 9.

## Accessories

### Outside and Inside Corner Posts

Corner posts are used to provide a finished edge at an inside or outside corner. The siding from adjoining walls fits neatly into the inside or outside corner post channels. Appropriate widths of channel openings are available to accommodate various configurations of siding.



### Trim and Molding

A complete line of accessories is used to give every installation a professional appearance, while providing a water-resistive facade. Some accessories include trim, starter strips, molding, F-channels, drip caps, and J-channels (Fig. 10). Each of these accessories will be addressed in more detail throughout this manual.

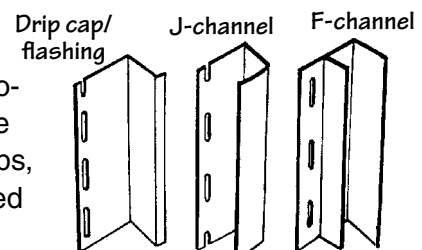

Figure 10.

**NOTE: Vinyl siding manufacturers produce various sizes of J-channels, corner posts, and other accessories. Remember to order accessories of the proper size to match the siding panels. Consult the manufacturer for the appropriate size.**

# GETTING STARTED

## Materials

### Sheathing/Backerboard

Vinyl siding should be applied over a sheathing that provides a smooth, flat surface. Consult local building codes for sheathing requirements. Vinyl siding must never be applied directly to studs without sheathing. As an alternative, installation of specific types of contoured foam underlayments for various styles of vinyl siding are available. Some manufacturers of vinyl siding do not recommend the use of drop-in backers with certain vinyl siding configurations.

### Water-Resistive Barrier

Vinyl siding should be installed over a continuous water-resistive barrier to stop the intrusion of incidental water. Refer to page 2 for more information on water-resistive barriers. Check your local building code for requirements in your geographic area.

### Flashing

Code-compliant flashing should be integrated with the water-resistive barrier and applied around windows, doors, and other openings. Flashing should also be applied to inside and outside corners, and the intersection of walls and roofing to prevent water infiltration.

## How to Measure

### Estimating Required Materials

- All houses can be broken down into shapes of rectangles or triangles, or a combination of both.
- The area to be sided can be determined by measuring the height and width of the house, including windows (Fig. 11).
- Total all of the measurements for the areas to be sided. Windows and doors are not usually deducted. Including them will provide an allowance factor for waste. If the windows and doors are extremely large (such as a garage or sliding glass doors), some deductions can be made (Fig. 12-14).
- To estimate the amount of starter strip required, measure the linear feet around the entire base of the house.
- Add siding to all material estimates to allow for waste, depending on the pitch of the roof and other house-specific factors.
- To estimate the total pounds of fasteners required, multiply the total square feet of siding by 0.005 for aluminum nails and 0.01 for roofing nails, staples, and screws.

Height \_\_\_ feet (meters) x width \_\_\_ feet (meters) =  
\_\_\_ square feet (square meters)

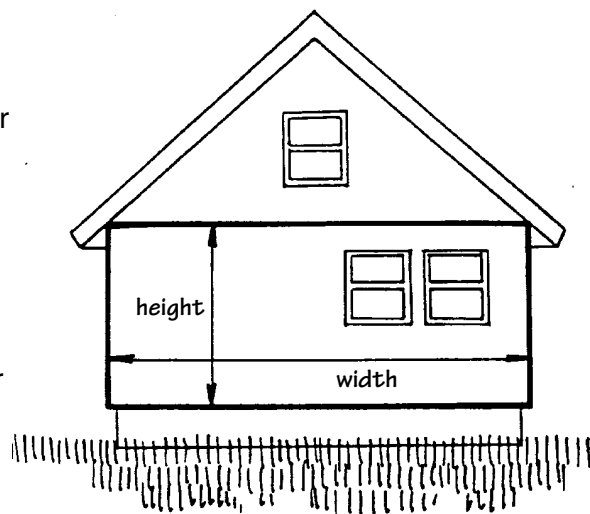

Figure 11. Wall areas

$\frac{1}{2}$  height x width = \_\_\_\_ area of gable (square feet/meters)

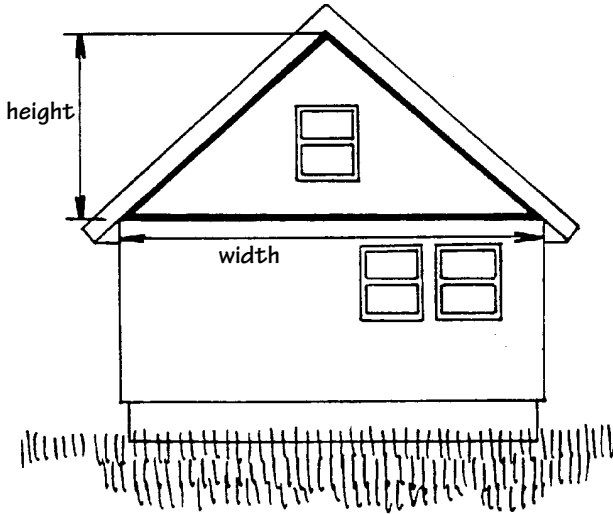

Figure 12. Gable areas

$\frac{1}{2} (A + B) \times C + \frac{1}{2} B \times D =$  \_\_\_\_ total area of gable (square feet/meters)

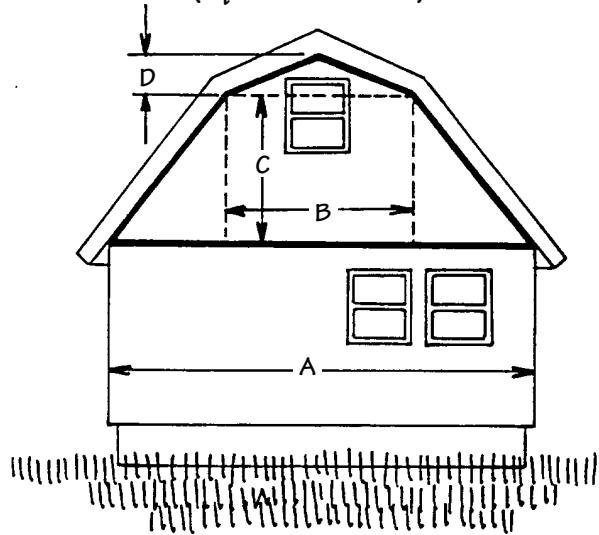

Figure 13. Gambrel roof house

- Every 100 square feet (9.29 square meters) is called a “square” for ordering purposes.

**NOTE:** The amount of siding needed/waste generated for a vertical siding job will be determined by the height of the wall versus the length of the panels.

$\frac{1}{2}$  height x width = \_\_\_\_ area of dormer (square feet/meters)

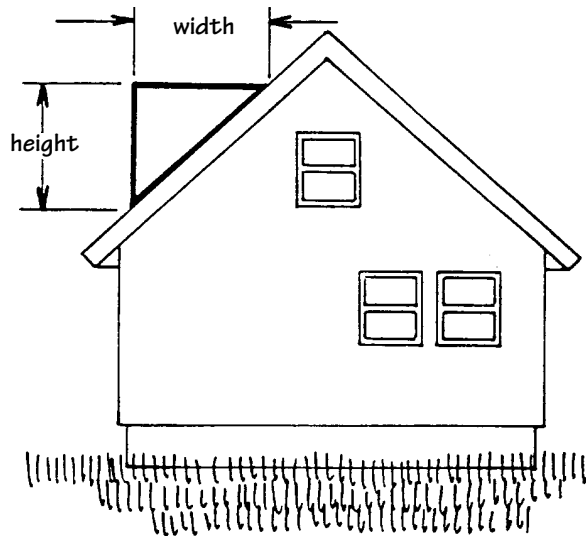

Figure 14. Dormer areas

# Estimating Worksheet

Use the following worksheet to estimate the required materials\*:

<b>Siding</b>	Walls	_____	square feet/meters
	Gable ends	_____	square feet/meters
	Dormer sides	_____	square feet/meters
	Upper gambrel walls	_____	square feet/meters
	Total wall surface area	_____	square feet/meters (A)
	Large areas not to be covered: (garage doors/sliding doors)	_____	square feet/meters
		x 0.50 =	
	Uncovered area	_____	square feet/meters (B)
	Subtract B from A for		
	<b>Total net surface area</b>	_____	square feet/meters
<b>Soffit</b>		_____	square feet/meters
<b>Porch ceiling</b>		_____	square feet/meters
<b>Lattice</b>		_____	linear feet/meters
<b>Accessories</b>	Starter strip	_____	linear feet/meters
	Utility trim	_____	linear feet/meters
<b>Receiving channel</b>	J-channel	_____	linear feet/meters
	Designer J-channel	_____	linear feet/meters
	Flexible J-channel	_____	linear feet/meters
	F-channel	_____	linear feet/meters
	3 1/2" /5" lineals	_____	linear feet/meters
	Dual undersill trim	_____	linear feet/meters
<b>Outside corners</b>	Outside corner post	_____	linear feet/meters
	Designer corner trim	_____	linear feet/meters
<b>Inside corners</b>	Inside corner post	_____	linear feet/meters
	J-channel	_____	linear feet/meters
<b>Other</b>	Soffit cove trim	_____	linear feet/meters
	Soffit double channel lineal	_____	linear feet/meters
	Light blocks	_____	
	Width of accessory recess opening:		
	(circle one)    1/2" (12.7mm)    5/8" (15.9mm)    3/4" (19mm)    1 1/4" (31.8mm)		
<b>Nails</b>	Pounds required		
	Length (1 1/2" minimum) (38.1mm)	_____	pounds
<b>Tools needed</b>	__ hammer	__ tin snips	__ tape measure
	__ chalkline	__ utility knife	__ level
	__ square	__ hacksaw	__ power saw
	__ nail hole slot punch	__ snap lock punch	
	__ unlocking tool	__ fine-tooth saw blade	

\* Add a factor of 10 percent to all material estimates to allow for waste.

## Fastener Choices

Use aluminum, galvanized steel, or other corrosion-resistant nails, staples, or screws when installing vinyl siding. Aluminum trim pieces require aluminum or stainless steel fasteners. All fasteners must be able to penetrate a minimum of 3/4" (19mm) into framing or furring (Fig. 15). (Review your local building codes for variations that may apply to specific geographic areas.)

### Nails

Nail heads should be 5/16" (7.9mm) minimum in diameter. Shank should be 1/8" (3.2mm) in diameter (Fig. 15).

### Screw Fasteners

Screw fasteners can be used if the screws do not restrict the normal expansion and contraction movement of the vinyl siding panel on the wall. Screws must be centered in the slot with approximately 1/32" (0.8mm) space between the screw head and the vinyl. Screws must be able to penetrate not less than 3/4" (19mm) into framing or furring and should be:

- Size #8, truss head or pan head
- Corrosion-resistant, self-tapping sheet metal type

Figure 15.

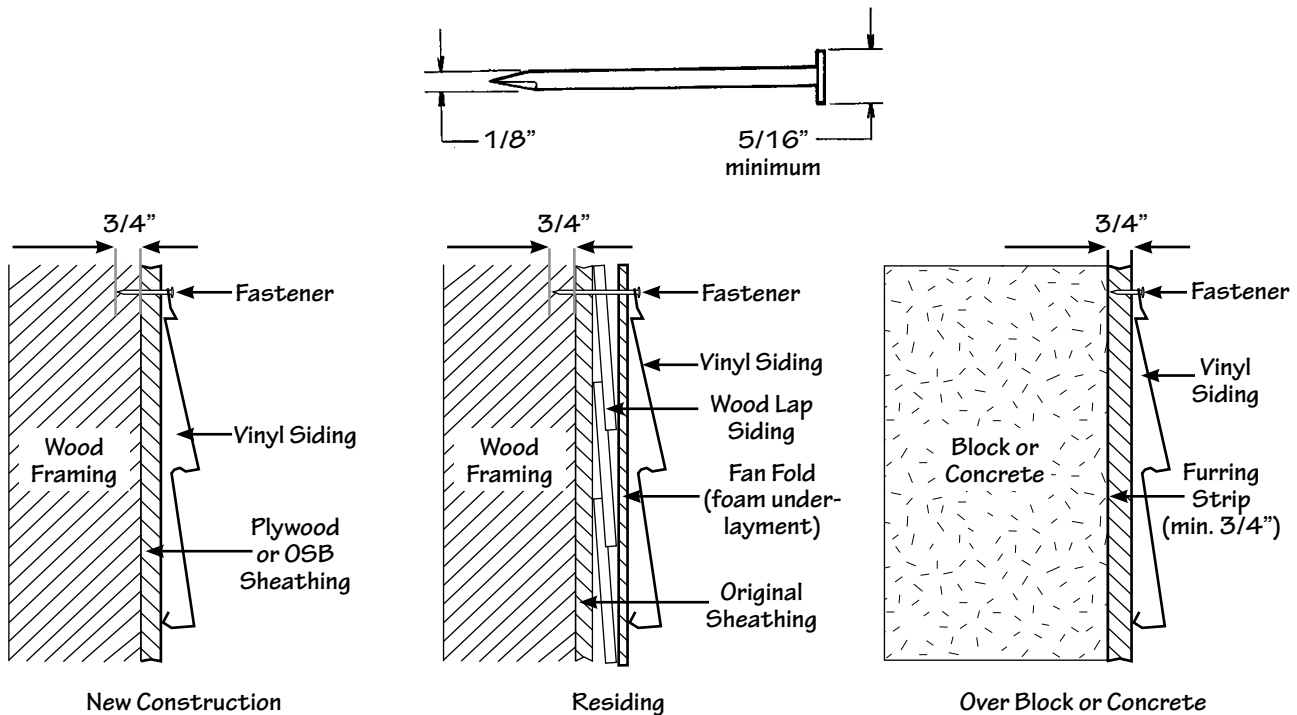

## Fastening Procedure

Vinyl siding can expand and contract 1/2" (12.7mm) or more over a 12' 6" (3.81m) length during normal, year-round changes in temperature. Whether using a nail, screw, or staple to fasten the siding, the following basic rules must be followed:

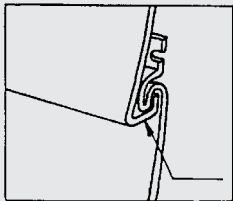

- Make sure the panels are fully locked along the length of the bottom, but do not force them up tight when fastening.

- Do not drive the head of the fastener tightly against the siding nail hem. Allow approximately 1/32" (0.8mm) clearance (the thickness of a dime) between the fastener head and the vinyl. **Tight nailing, screwing, or stapling will cause the vinyl siding to buckle with changes in temperature (Fig. 16).**
- When fastening, start in the center of the panel and work toward the ends.
- Center the fasteners in the slots to permit expansion and contraction of the siding (Fig. 17).
- Drive fasteners straight and level to prevent distortion and buckling of the panel (Fig. 18).
- Space the fasteners a maximum of 16" (406mm) apart for the horizontal siding panels, every 12" (305mm) for the vertical siding panels, and every 8" to 12" (203mm to 305mm) for the accessories. These distances may be increased if the manufacturer permits greater spacing based on windload testing. Start fastening vertical siding and corner posts in the top of the uppermost slots to hold them in position. Place all other fasteners in the center of the slots (Fig. 19).
- If a nail slot does not allow centering/securing into a nailable surface, use a nail hole slot punch to extend the slot and allow centering of the fastener.

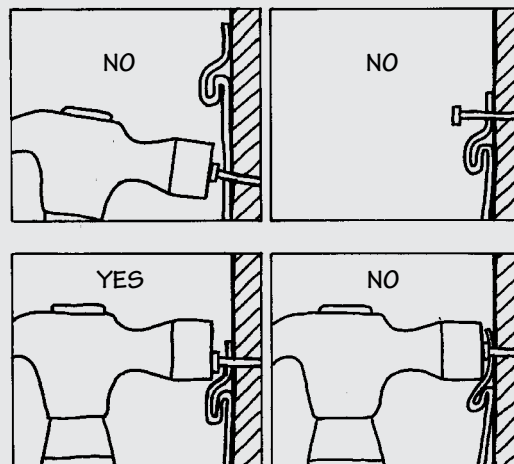

Figure 16.

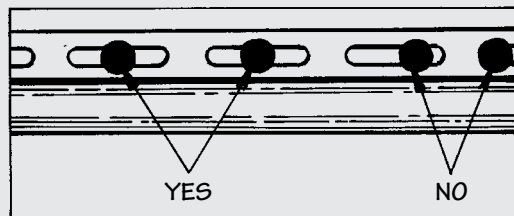

Figure 17.

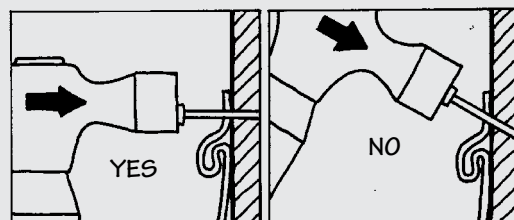

Figure 18.

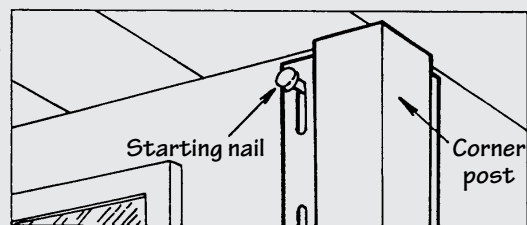

Figure 19.

## Staples

If staples are being used instead of nails or screws, they must (Fig. 20):

- Not be less than 16-gauge semi-flattened to an elliptical cross-section.
- Penetrate not less than 3/4" (19mm) into framing or furring.
- Be wide enough in the crown to allow free movement of the siding (approximately 1/32" [0.8mm] away from the nailing hem).

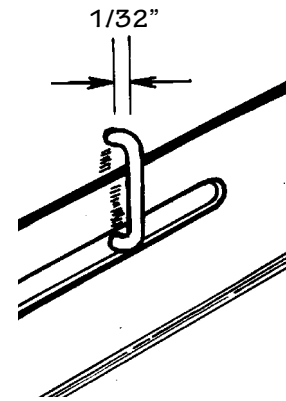
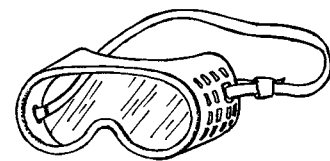

Figure 20.

## Cutting the Siding

When cutting vinyl siding or soffit, follow these guidelines:

- Safety goggles are always recommended for all cutting and nailing operations. As on any construction job, use proper safety equipment and follow safe construction practices.
- With a circular saw, install the fine-tooth (plywood) blade backwards on the saw for a smoother, cleaner cut, especially in cold weather (Fig. 21). Cut slowly. Do not attempt to cut materials other than vinyl with a reversed direction saw blade.



**Caution! Use of a backwards blade on any other materials could be unsafe.**

- With tin snips, avoid closing the blades completely at the end of a stroke for a neater, cleaner cut (Fig. 22).
- With a utility knife or scoring tool, score the vinyl face up with medium pressure and snap it in half. It is not necessary to cut all the way through the vinyl (Fig. 23).

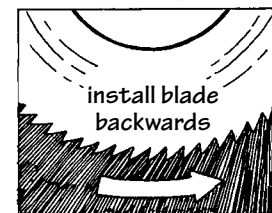

Figure 21.

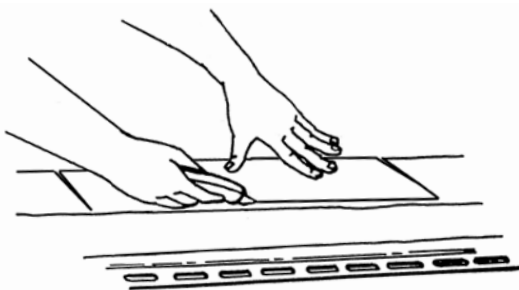

Figure 23.

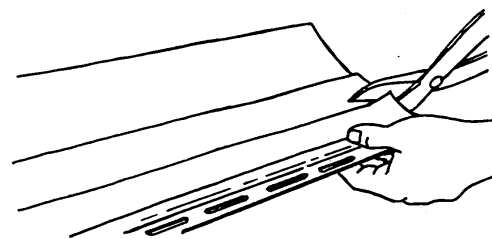

Figure 22.

## Preparing the Walls

A flat, level wall surface is necessary for proper installation of vinyl siding. Install flashing **before** starting to apply the siding.

Unless already installed, a water-resistive barrier should be applied to the house prior to installing vinyl siding. Refer to page 2 for more information on water-resistive barriers. Consult your local building code for requirements in your geographic area.

### New Construction

- Tip: To reduce the possibility of floor-plate compression, drywall, roofing, or other heavy building materials should be installed or stored throughout the house prior to the installation of vinyl siding. Floor-plate compression can result in buckled siding at the intersection of the floor and the wall.

### Residing

- Nail down loose boards of existing siding, and replace any rotten ones (Fig. 24). **Do not install vinyl siding over rotting wood.**
- Scrape off loose caulk and re-caulk around windows, doors, and other areas to protect from moisture penetration.
- Remove all protrusions such as gutters, downspouts, and light fixtures.
- Check all walls for evenness and install furring strips where necessary. When installing furring strips, please take appropriate measures to establish a smooth and continuous surface. (Fig. 25).

**NOTE:** In cases where the lower portion of a horizontal siding panel must be trimmed so that it may be installed over steps, porches, etc., the panel should be built out (“furred”) for proper angle and rigidity. Utility trim can be used to seal the cut edge of the panel and then secured to the wall.

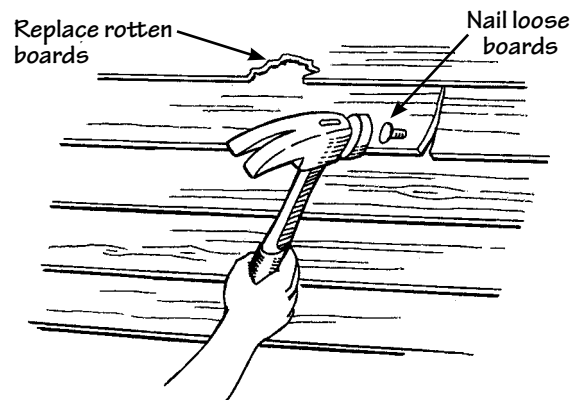

Figure 24.

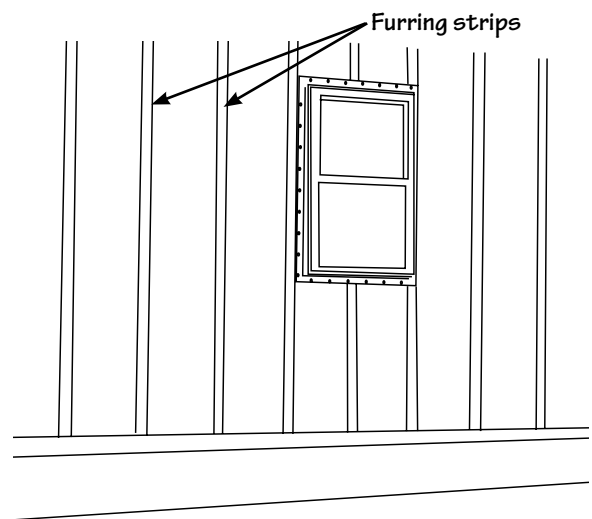

Figure 25.

# INSTALLING ACCESSORIES

Before the siding itself can be hung, a number of accessories must be installed first, including starter strips, corner posts, window flashing, trim, and J-channels over the roof lines.

## Outside and Inside Corner Posts

- A water-resistive material should be used to flash the inside and outside corners a minimum of 10" (254mm) on each side before installation of the corner posts (Fig. 26).

**NOTE: Install vinyl soffit and fascia before installing outside and inside corner posts.**

- Place the corner post in position, allowing a 1/4" (6.4mm) gap between the top of the post and the eave or soffit. Position a nail at the top of the upper slot on both sides of the corner post, leaving a gap of approximately 1/32" (0.8mm) between the nail heads and the corner posts. The corner post hangs from these nails. The balance of the nailing should be in the center of the slot, 8" to 12" (203mm to 305mm) apart, again leaving 1/32" (0.8mm) between the nail head and the corner post. This allows for the expansion and contraction to occur at the bottom. The corner post should extend 3/4" (19mm) below the starter strip. Make sure the posts are plumb (i.e., vertically straight) (Fig. 27 and 28).

- If more than one length of corner post is required, overlap the upper piece over the lower piece by cutting away 1" (25.4mm) of the nailing flange on the top piece. Overlap 3/4" (19mm), allowing 1/4" (6.4mm) for expansion. This method will produce a visible joint between the two posts, but will allow water to flow over the joint, reducing the chance of water infiltration.

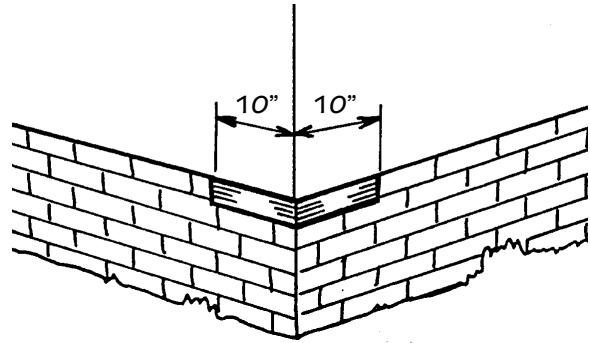

Figure 26.

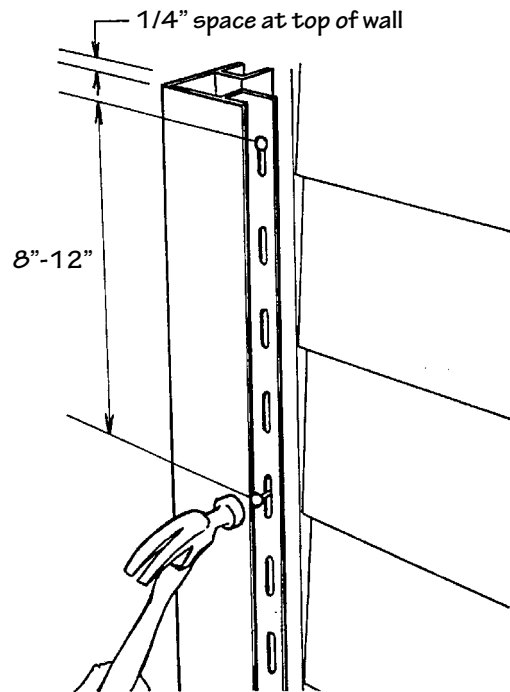

Figure 27.

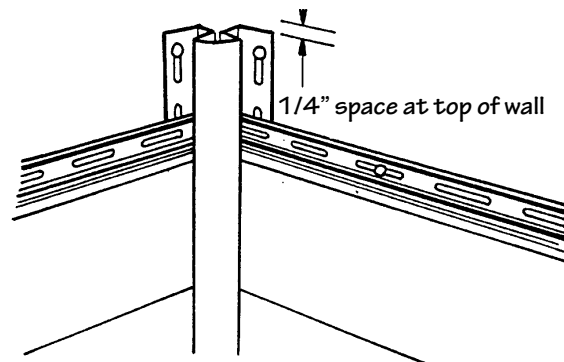

Figure 28.

## Starter Strip

In order for the siding to be installed properly in a level fashion, the starter strip at the bottom of the wall must be level.

- Determine the lowest point of the wall that will be sided; from that point, measure up 1/4" (6.4mm) less than the width of the starter strip and partially drive a nail at one corner.
- Attach a chalkline; go to the next corner and pull the line taut.
- Make sure the line is level by using a line level or a 4' (1.2m) level.
- Snap the chalkline and repeat the procedure around the entire house.
- Optional method to determining the position of the starter strip in new construction and some residing applications: Measure down from the soffit at one corner of the house to the top of the foundation and subtract 1/4" (6.4mm) less than the width of the starter strip. Make a mark on the wall and record the measurement. Transfer the measurement to the other corner of the wall. Snap a chalk line in between the corners at the marks. Repeat the procedure around the entire house.
- Using the chalkline as a guide, install the top edge of the starter strip along the bottom of the chalkline, nailing at 10" (254mm) intervals. Allow space for the corner posts, J-channels, etc.
- Keep the ends of starter strips at least 1/4" (6.4mm) apart to allow for expansion (Fig. 29).
- Nail in the center of the starter strip nailing slots.
- For backed siding, the starter strip needs to be spaced away from the wall to accommodate the thickness of the backing on the siding. Consult the manufacturer's instructions for specific materials or techniques.

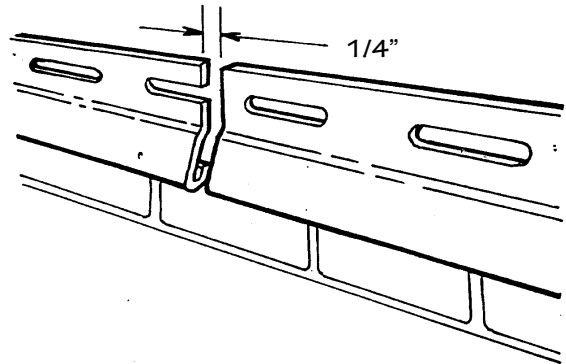

Figure 29.

**NOTE:** When insulation or backerboard is used, fur the starter strip, if necessary, to accommodate the thickness of the siding. For a vertical siding starter methods, see the section on vertical siding.

**NOTE:** In certain situations, it may be necessary to use J-channel as a starter strip; remember to drill minimum 3/16" (4.8mm) diameter weep holes no more than 24" (610mm) apart.

## Windows, Doors, and Roof Lines

### Flashing New Window Installations

If installing both a new window and flashing, refer to window manufacturer's instructions and *ASTM E2112, Standard Practice for Installation of Exterior Windows, Doors and Skylights* for the proper flashing installation method for the window type and wall configuration on the project.

### Flashing Previously Installed Nail Fin Windows

If a nail fin (in new construction) window has been previously installed without flashing, the following instructions should be followed:

- Apply a continuous bead of sealant to the nailing flange of the sill in a manner that covers the nails and nail slots. Apply a minimum of 9" (229mm) wide horizontal sill flashing level with the bottom edge of the existing window by pressing the flashing into the sealant bead at its top edge. Cut the sill flashing long enough to extend a minimum of 9" (229mm) beyond each jamb. Fasten the sill flashing at the bottom and side edges (Fig. 30).
- Apply a continuous bead of sealant to the nailing flange of the jambs in a manner that covers the nails and nail slots. Continue the bead of sealant at the jambs vertically a minimum of 8 1/2" (216mm) above the head of the window to allow for bedding the top portion of the jamb flashing into sealant in the next step. Install the jamb flashing by pressing the flashing into the sealant beads at the window jambs. Extend the bottom edge of the jamb flashing approximately 1/2" (12.7mm) short of the sill flashing edge, and extend the top edge approximately 8 1/2" (216mm) beyond the head of the window, where the head flashing will be placed next. Fasten the jamb flashing along the edges further most from the window (Fig. 31).

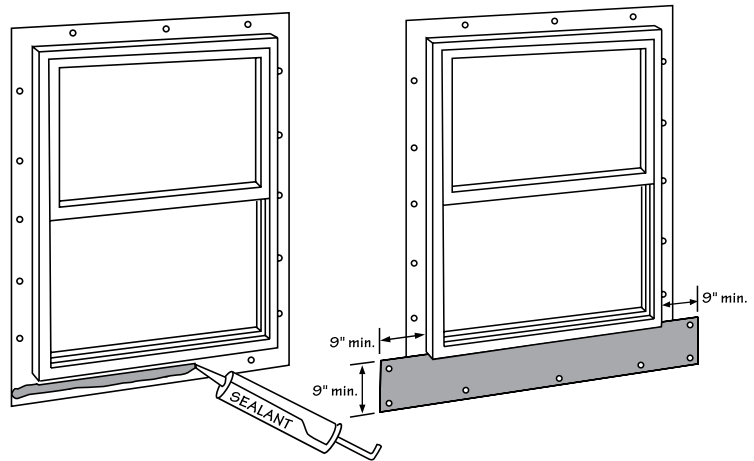

Figure 30.

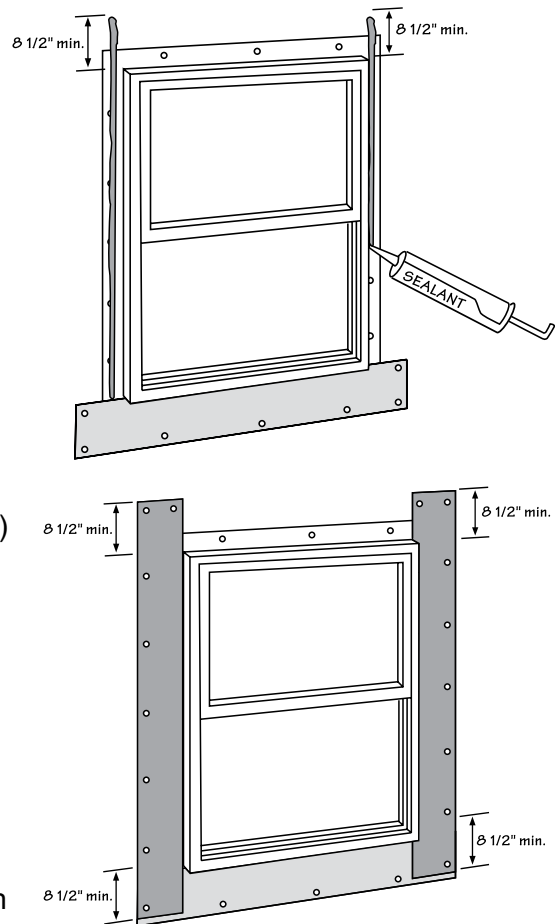
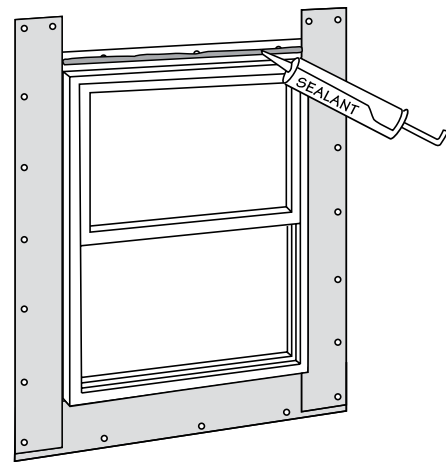

Figure 31.

**NOTE: Sealant should be compatible with window, flashing, and water-resistive barrier materials. Contact sealant manufacturer for job-specific recommendations.**

- Apply a continuous bead of sealant to the nailing flange of the head in a manner that covers the nails and nail slots. Add an additional bead of sealant horizontally, in line with the top of the head flashing. Install the head flashing by pressing the bottom edge of the flashing into the sealant bead previously applied across the mounting flange. Extend the ends of the head flashing approximately 1" (25.4mm) beyond the jamb flashing at each end. Fasten the head flashing into place along the top edge (Fig. 32).



### Flashing Previously Installed Window with Exterior Casing (Brick Mold)

If a window with exterior casing (brick mold) has been previously installed without flashing, the following instructions should be followed:

- Ensure that exterior casing is sealed to the exterior sheathing or water-resistive barrier with a good quality sealant.
- Cover the exterior casing with aluminum or vinyl trim sheet. This can be accomplished by using a portable field brake and bending instructions from the brake manufacturer. The trim sheet should be installed in weatherboard fashion. The bottom piece should be installed first, and each piece should overlap the piece below wherever they join.
- Install rigid head flashing (drip cap) on top of the top piece of exterior casing, covering trim sheet installed in the previous step. The ends of the rigid head flashing must extend to the outer edges of the exposed legs of the side J-channels. Cut a notch on the ends of the rigid head flashing and bend them down over the sides of the exterior casing. The rigid head flashing must be sealed to the exterior sheathing and to the top of the exterior casing (Fig. 33).

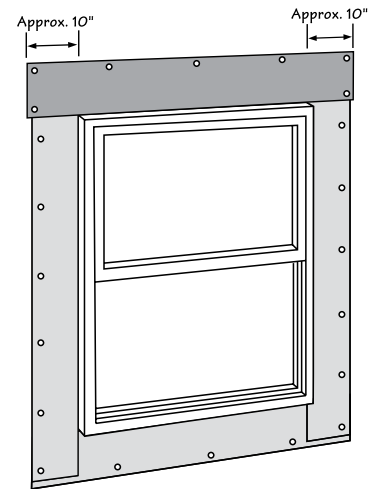

Figure 32.

### Trim

J-channel is used around windows and doors to receive the siding. Follow the steps below when applying trim.

- Cut and bend the tab of the top piece of J-channel down to provide flashing over the side J-channel.
- Fold the bottom end of the side piece of J-channel inward at the bottom of the window, to fit over the existing J-channel to prevent water from entering under the sill.
- Cut the side J-channel members longer than the height of the window or door, and notch the channel at the top.

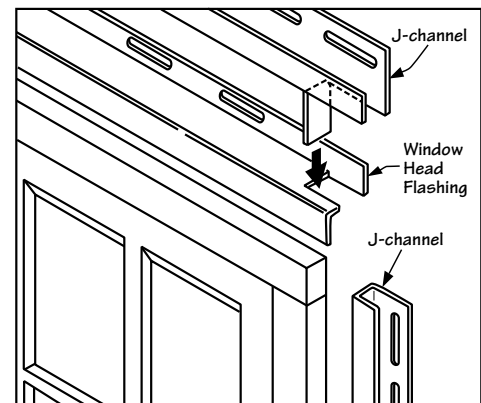

Figure 33.

- Miter cut the free flange at a 45° angle and bend the tab down to provide flashing over the side members (Fig. 33). A similar miter and tab may be provided at the bottom of the window, depending on the sill's condition. The J-channel should fit snug to the window.

### J-Channel Over Roof Lines

Install the flashing before the J-channel to prevent water infiltration along the intersection of a roof and wall.

- Keep the J-channel a minimum of 1/2" (12.7mm) from the roof line. Chalk a straight line up the roof flashing to guide J-channel installation. Tip: You can use another J-channel laid over the shingles as a spacer to create the straight line desired.
- Overlap the J-channel (lapping the upper piece over the lower piece) if it is necessary to use more than one piece.
- Extend the J-channel past the edge of the roof, channeling water into the gutter, in order to ensure proper runoff.
- With dark shingles, or a south or west exposure, it is recommended to either use a metal J-channel or to install the vinyl J-channel as far away from the roofing as is aesthetically acceptable, having first ensured that there is sufficient flashing behind the J-channel to prevent water infiltration.
- Fasten the nail, screw, or staple that is closest to the roof line at the far end of the nail hem slot, to ensure that siding will expand away from the J-channel (Fig. 34).

**NOTE: Vinyl J-channels should not be in direct contact with roofing shingles, since the shingles may transfer enough heat to the vinyl J-channel to cause its distortion.**

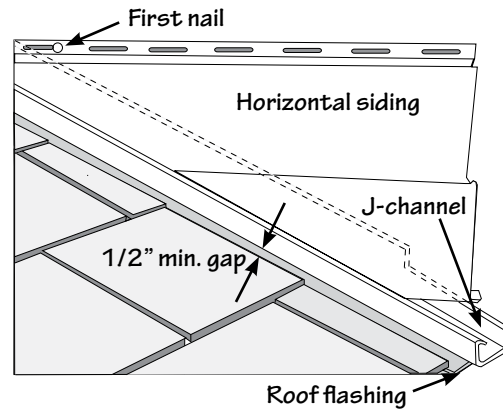

Figure 34.

### Gable and Trim

Before applying siding to the gables, the J-channel should be installed to receive the siding at the gable ends (Fig. 35):

- Where the left and right sections meet at the gable peak, let one of the sections butt into the peak with the other section overlapping.
- A miter cut should be made on the face flange of this piece for better appearance.
- Fasten the J-channel every 8" to 12" (203mm to 305mm).
- If more than one length of J-channel is required to span a wall surface, be sure to overlap the J-channels by 3/4" (19mm).

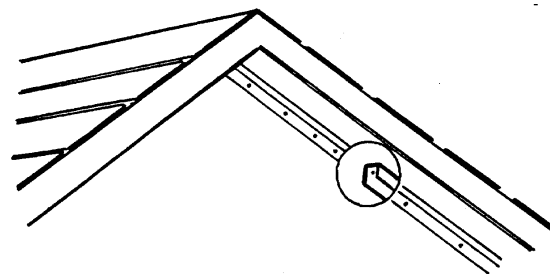

Figure 35.

# HORIZONTAL SIDING INSTALLATION

## Installing Panels

- The first course (row of panels) should be placed in the starter strip and securely locked along the entire length of the siding panel. Make sure the panel is securely locked before fastening.
- Fasten the panels in the center of the nailing slots (see pages 14 and 15 for specific information on fastening and fasteners). Allowance should be made for expansion and contraction by leaving a 1/4" (6.4mm) gap between the siding and all corner posts and channels. Increase to 3/8" (9.5mm) when installing in temperatures below 40° F (4.4° C). If the panels are 20 feet (6.1 meters) or longer, refer to the manufacturer's instructions for how to increase the gap.
- Do not drive the head of the fastener tightly against the nail slot. Leave approximately 1/32" (0.8mm) between the fastener head and the vinyl (about the thickness of a dime).
- Do not force the panels up or down when fastening. Panel locks should be fully engaged; however, the panels should not be under vertical tension or compression when they are fastened.
- Since vinyl siding moves as the temperature changes, make certain that the vinyl panels can move freely in a side-to-side direction once fastened.
- Check every fifth or sixth course for horizontal alignment (Fig. 36). Also check siding alignment with adjoining walls.
- When panels overlap, make sure they overlap by one half the length of the notch at the end of the panel, or approximately 1" (25.4mm) (Fig. 37).
- When lapping horizontal foam backed siding, slide panels together until the backing forms a continuous coverage (Fig. 38). Do not leave a gap between the backing of each panel.
- Stagger the siding end laps so that no two courses (rows of panels) are aligned vertically, unless separated by at least three courses.
- Always overlap joints away from entrances and/or away from the point of greatest traffic. This will improve the overall appearance of the installation (Fig. 37).
- Avoid using panels shorter than 24" (610mm).

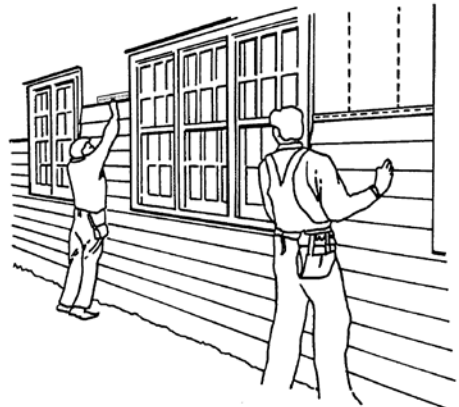

Figure 36.

Overlap away from areas of high traffic (e.g., doors)

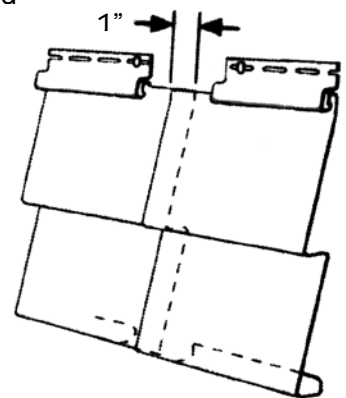

Figure 37.

Foam backer touching

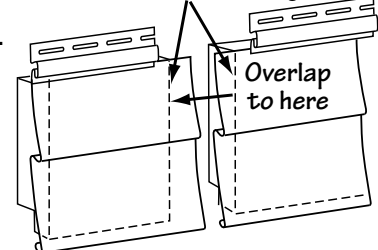

Figure 38.

## Fitting Siding Around Fixtures

Use a commercially available trim ring (Fig. 39) to fit siding to a penetration such as a faucet or railing attachment, following the manufacturer's installation instructions. If a commercial trim ring is not available for the application, refer to Fig. 40, which illustrates how to fit the siding to the penetration. In addition, the following tips are suggested:

- If hand-fitting to the fixture, always begin a new course of siding at the fixture.
- Cut an opening  $1/4"$  (6.4mm) bigger than the fixture or the trim ring.
- When cutting, match the shape and contour of the obstruction.
- For backed siding, due to the thickness of the backing, it may be necessary to build out the fixture or window and door trim to achieve the desired appearance.

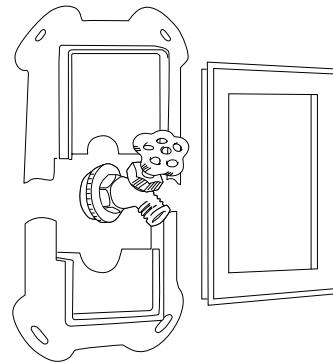

Figure 39.

## Fitting Under Windows

To mark the section to be cut, perform the following:

- Hold the panel under the window and mark the width of the window opening on the panel. Add approximately  $1/4"$  (6.4mm) to both sides to allow for expansion and contraction of the siding. These marks represent the vertical cuts (Fig. 41).
- Lock a small piece of scrap siding into the lower panel next to the window. This will be used as a template for the horizontal cuts. Mark it  $1/4"$  (6.4mm) below the sill height.
- Transfer the horizontal measurement to the panel, which will be installed under the window. Measurement may not be the same on both sides of the window.
- Cut the panel with tin snips and a utility knife.

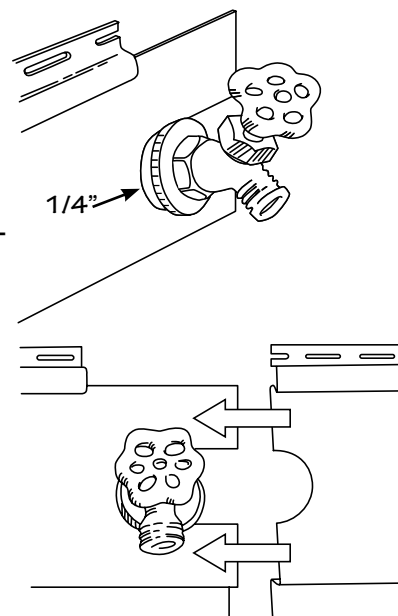

Figure 40.

The cut panel is now ready for installation under the window. Perform the following:

- Using a snap lock punch, punch the vinyl siding along the cut edge every 6" (152mm) so the raised lug is on the outside face.
- Install utility trim under the window, as a receiver for the cut siding. Utility trim is used any time the top lock has been removed from the siding. Furring may be needed to maintain the face of the panel at the desired angle.

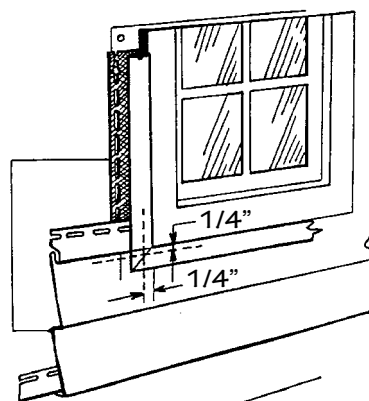

Figure 41.

- Install the siding panel, making sure the lugs (from the snap lock punch) lock into the utility trim (Fig. 42).

## Sidewall Flashing at Roof Lines

- Run the siding until the last full course under the roof area.
- Cut a diverter from aluminum trim sheet, making sure it sits on the nail hem of the last full course (Fig. 43). Make sure the diverter is placed inside the receiving pocket of the vertical J-channel and is tucked behind the nail hem of the J-channel following the roofline for best drainage.
- If a water-resistive barrier is present, a cut should be made in that barrier to allow the diverter to slip behind the roof step flashing and the J-channels. That cut will need to be sealed with tape (approved by the housewrap manufacturer) once the diverter is installed.
- As an alternative to the diverter, create a “kickout” from metal flashing, as shown in Fig. 44.

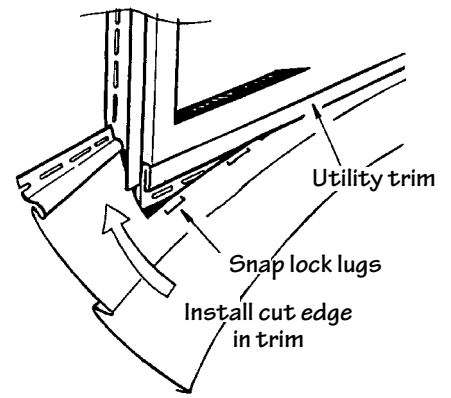

Figure 42.

**NOTE:** “Kickout flashing” (Fig. 44) is an additional flashing strip that extends beyond the edge of the fascia that is required in some cold-climate localities.

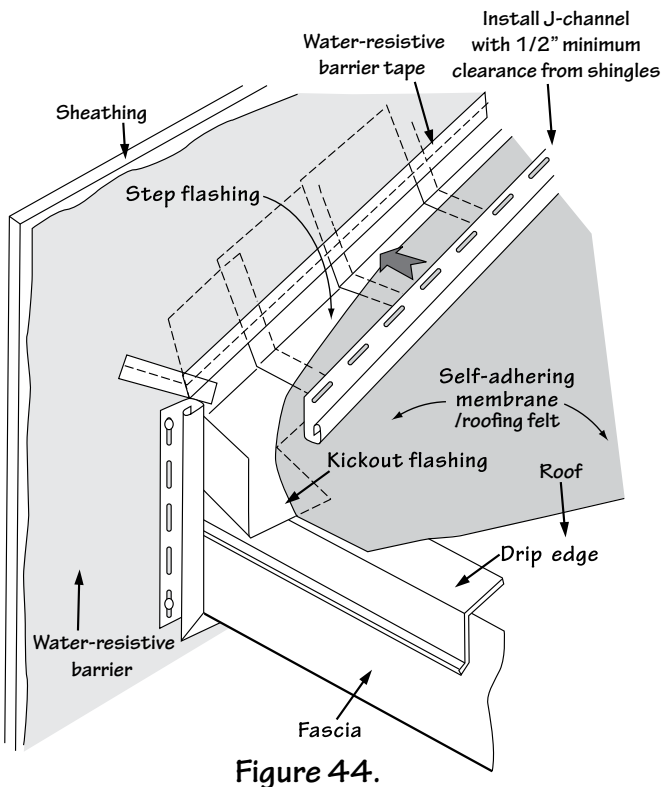

Figure 44.

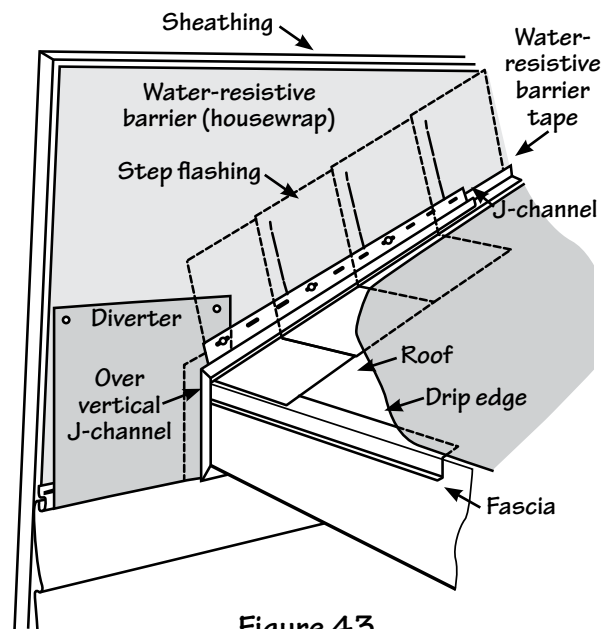

Figure 43.

## Finishing at the Top

Before the final course of siding is installed on the wall, any soffit accessories that will be used on the eaves must be installed. See the soffit installation section.

### Gable Ends

To install around gable ends, make a pattern that duplicates the slope of the gable (Fig. 45):

- Lock a short piece of siding into the gable starter course (i.e., the last course before the gable starts).
- Hold a second piece of siding against the J-channel at the slope of the gable. Mark the slope with a pencil on the short piece of siding. Check the angle template every few courses.
- Remove the short piece and cut along the pencil line as a pattern for the gable angle cuts. Repeat the procedure on the opposite side of the gable.
- It may be necessary to fasten the last panel at the gable peak with a trim nail. Use a 1 1/4" to 1 1/2" (31.8mm to 38.1mm) nail. This is one of the few times a nail should be placed in the face of the vinyl siding (Fig. 46).

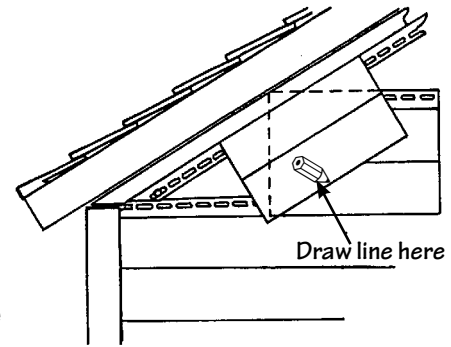

Figure 45.

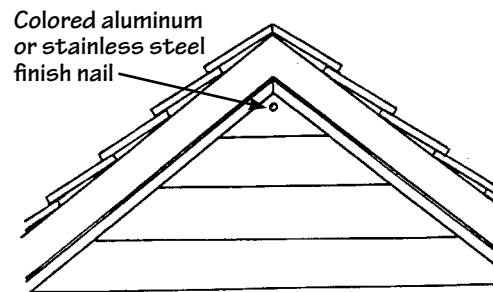

Figure 46.

### Eaves Treatment

The last course of siding may be cut to fit the eaves opening (Fig. 47).

- Measure from the soffit to the base of the upper lock on the previous course of panels. Subtract 1/4" (6.4mm). Mark this dimension on the panel to be cut, measuring from the bottom edge of the panel. It is a good idea to check the dimension in several locations along the length of the wall.
- Using a snap lock punch, punch the vinyl siding along the cut edge every 6" (152mm), so the raised lug is on the outside face.
- Push the siding into the utility trim that has been nailed in place along the top of the wall. Furring may be needed to maintain the face of the panel at the desired angle. The raised lugs will catch and hold the siding firmly in place.

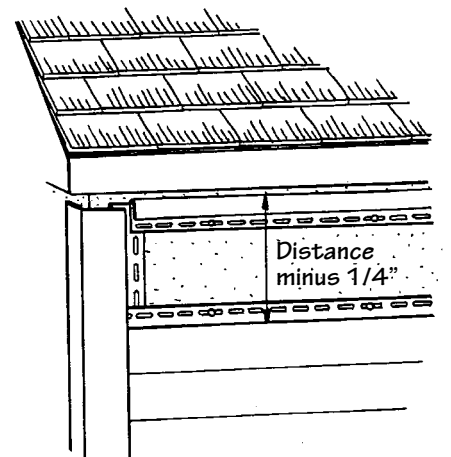

Figure 47.

### Low-Pitch Roof

When the majority of the nail hem has been removed, such as is necessary when fastening siding under a low-pitch roof, some manufacturers offer specialty products. Contact your manufacturer for an appropriate product or installation method.

For example, use a two-piece cover/receiver along the rake (Fig. 48). Install the receiver flush with the top of the wall. Punch nail slots along the top edge of the panel every 16" (406mm). Use those nail slots to attach the panel to the wall. Snap the cover into place over the nails.

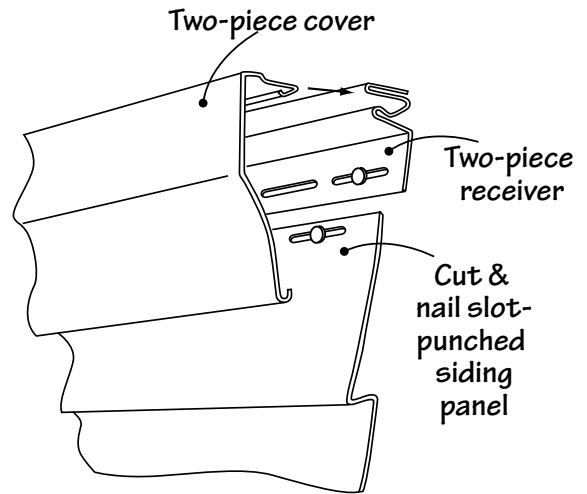

Figure 48.

### Transition from Horizontal to Vertical

- Finish the last course of horizontal siding with the J-channel and/or finish trim. Install a drip cap and a J-channel. The top piece of J-channel must have minimum 3/16" (4.8mm) diameter weep holes drilled no more than 24" (610mm) apart to allow for water runoff.

### Transition from Brick to Vinyl Siding

- Caulk where the sheathing meets the brick or stone exterior. Flashing should be caulked where it meets the brick or stone and a drip cap should be in place.
- If horizontal siding is used, a J-channel or starter strip may be used. If starter strip is used, it is necessary to provide at least 3/8" (9.5mm) clearance for proper engagement of the siding.
- Use a J-channel to receive vertical siding; remember to drill minimum 3/16" (4.8mm) diameter weep holes no more than 24" (610mm) apart.

## VERTICAL SIDING AND ACCESSORIES INSTALLATION

### Preparation

See section "Preparing the Walls" on page 17. When installing vertical siding, however, follow these additional preparatory steps:

- Install horizontal furring strips, 12" (305mm) on center, or a solid nailable sheathing prior to the siding, if needed, to level the surface or provide sufficient material for fastener penetration.
- Snap a level chalkline around the base of the sidewalls. Typically, the chalkline is positioned so that the bottom of the J-channel that will be installed like a starter strip is 1/4" (6.4mm) below the lowest point on the wall that will be sided. (See the "Installing Accessories" section for tips on snapping a chalkline.) Install J-channel along the chalkline as a receiver for the vertical siding.

## Accessories

As with horizontal siding, when installing vertical siding it is necessary to install several accessories first, including corner posts and window, door, and roof trim.

### Outside and Inside Corner Posts

- Leave 1/4" (6.4mm) gap at the top of corner posts.
- Place the first nails in the uppermost end of the top nail slots to hold them in position (Fig. 49). Place all other nails in the center of the slots. Nails should be 8" to 12" (203mm to 305mm) apart.
- Corner posts should extend 1/4" (6.4mm) below the siding. Do not nail tightly; the corner post should move.
- With backed siding, use the manufacturer's approved corner post to receive the additional thickness of the backing. If one is not available, shim the post with foam or other shim material. Always consult the manufacturer's instructions first.

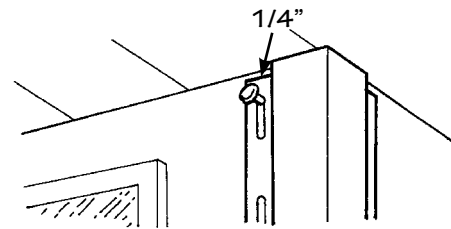

Figure 49.

**NOTE: Install vinyl soffit and fascia before installing outside and inside corner posts.**

### Bottom Receiver

- Position the top edge of a J-channel or vertical base along the previously snapped chalkline. Remember to drill minimum 3/16" (4.8mm) diameter weep holes no more than 24" (610mm) apart.
- Fasten every 8" to 12" (203mm to 305mm). Use the center of the nail slots. All vinyl should be fastened securely but not tightly. Sideways movement should not be restricted. Leave 1/4" (6.4mm) gaps at the corner posts (Fig. 50). Where lengths adjoin, trim the nailing flange 1" (25.4mm) and overlap 3/4" (19mm) to produce a neat joint (Fig. 51).

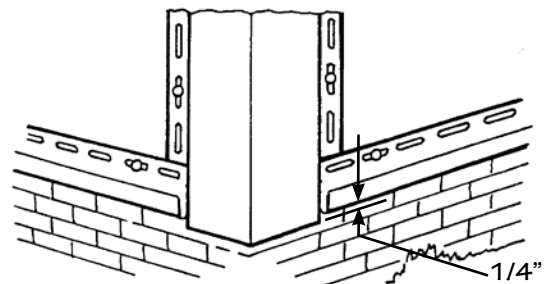

Figure 50.

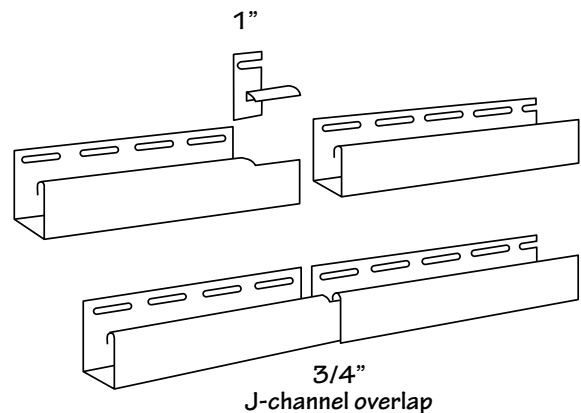

Figure 51.

### Window, Door, and Roof Trim

Install J-channel at the tops of the sidewalls. At the gable ends, snap a level chalkline along the base of the gable and install J-channel. Overlap where necessary and allow for expansion (Fig. 52).

After installing flashing, trim around all windows and doors using J-channel. The following sequence is suggested:

- Cut a J-channel for the bottom of the window, as wide as the frame, and install it.

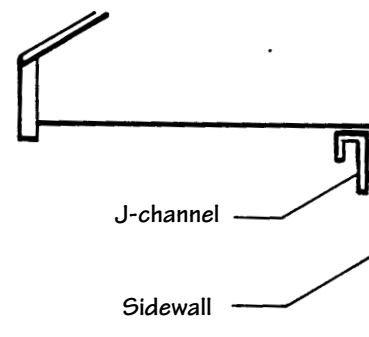

Figure 52.

- Cut side J-channels the length of the frame plus the width of the top and bottom J-channel. Cut and bend tabs (Fig. 53) into the bottom channel. Install the side channels.
- Cut the top J-channel the width of the frame plus the width of the side J-channels. Notch the top J-channel on each end, bend the tabs into the side J-channel, and fasten the top J-channel (Fig. 54).
- A miter cut and tab can be provided at the bottom of the window (see page 21), depending on the sill's condition.

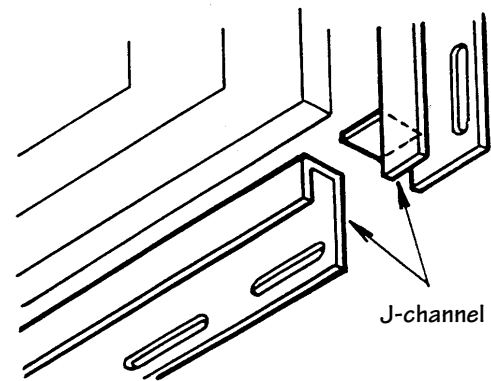

Figure 53.

## Sidewalls

- To create a balanced appearance (Fig. 55), divide the length of the wall by the exposure of the vertical panel to be used. For example, if the wall requires 20 full panels plus an additional 8" (203mm), then the first and last pieces installed would be cut to a new width of 4" (102mm). Make sure to allow for proper depth in the receiving channels of the accessories at both ends when measuring.
- To install the siding, if partial panels are required, mark the line to cut by measuring from the edge of the lock of the panel and cut the panel to the proper width. This will leave a panel with an intact nail hem and proper exposure.

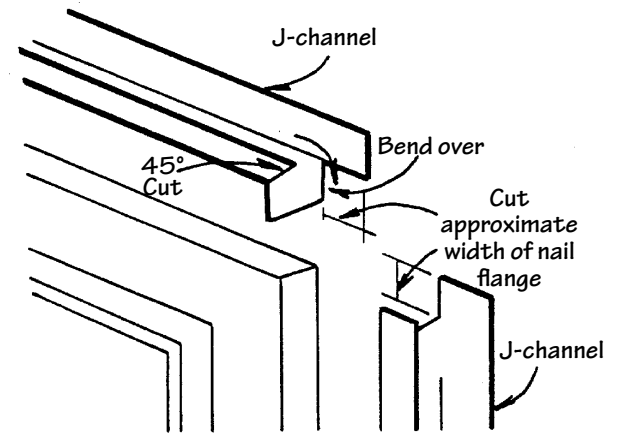

Figure 54.

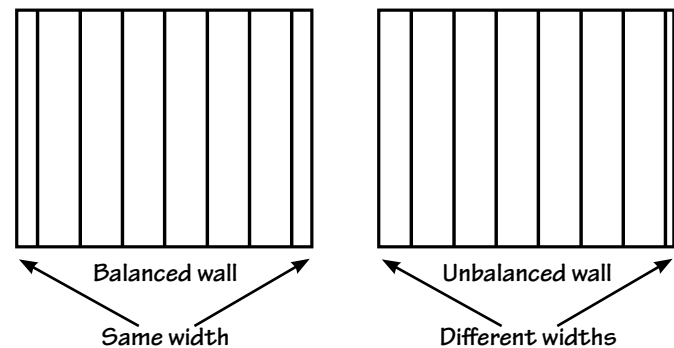

Figure 55.

- Use a snap lock punch to create tabs every 6" (152mm) along the cut edge. Depending on where the cut occurs, you may be required to install utility trim inside the receiving pocket of the J-channel or corner post, which receives the vertical siding (Fig. 56). You may also need to shim the utility trim outward to a level equal that of the siding panel face, in order to keep a level appearance.

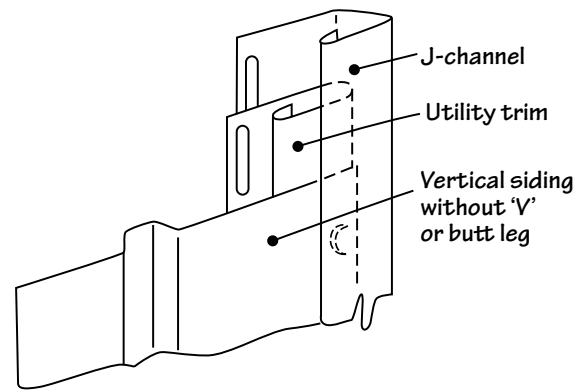

Figure 56.

- To complete this starting piece, snap the tabs into the utility trim, plumb the panel level, and begin securing by placing a fastener at the top of the topmost full nail slot, allowing for 1/4" (6.4mm) upward movement and 3/8" (9.5mm) downward. (Some manufacturers' vertical siding instructions are different; consult with the manufacturer for specific installation instructions). Continue securing with fasteners centered in the nail slots not more than 12" (305mm) apart.

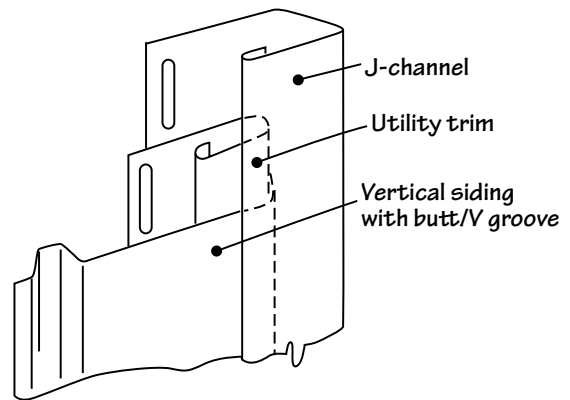

Figure 57.

- Install successive panels by securing from the topmost full nail slot downward, as described above, then 12" (305mm) on center for the rest of the panel. Around windows, doors, and fixtures, allow 1/4" (6.4mm) clearance in receiving channels (increase to 3/8" [9.5mm] if installing below 40° F [4.4° C]). When the panels are cut in the "V" groove or on the flat surface of the panel to accommodate an opening, install utility trim to properly secure panels, as described above (Fig. 57). Check the plumb of the installation every few panels to maintain the best appearance.

- If it will take more than one course to span the height of the house, terminate the first course into an inverted J-channel (Fig. 58), allowing 1/4" (6.4mm) for expansion. Install head flashing on top of the J-channel and install a second J-channel facing upward. Begin the second course leaving a 3/8" (9.5mm) gap from the bottom of the panel to the J-channel.

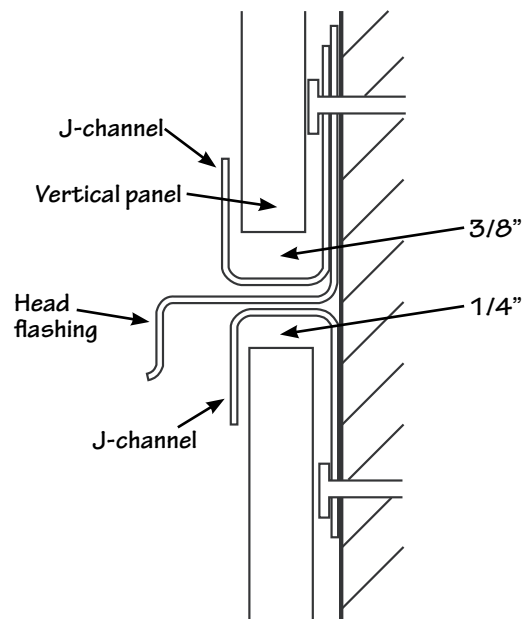

Figure 58.

- The final siding panel should be the same width as the starting course. Depending on where the cut occurs, it may be necessary to install utility trim inside the receiving pocket of the J-channel or corner post that receives the vertical siding (Fig. 59). It may also be necessary to shim the utility trim outward to a level equal that of the siding panel face, in order to keep a level appearance.

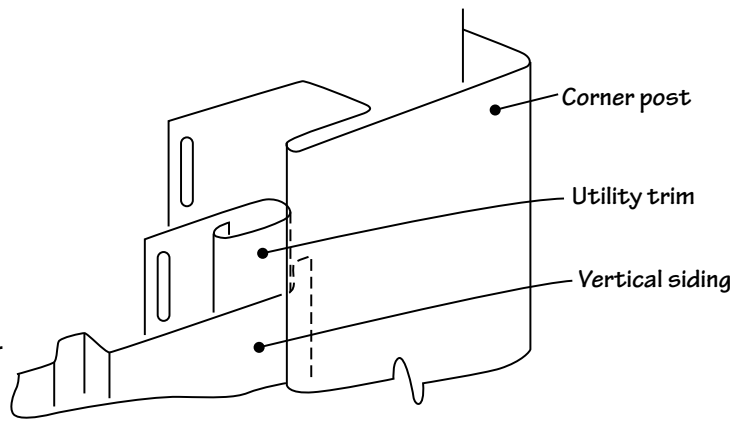

Figure 59.

- Cut the panel to proper width and create tabs every 6" (152mm) using a snap lock punch. Finish the installation by inserting the tabs of the properly sized panel into the utility trim. It may be necessary to place a color-matched trim nail near the top of the panel and inside the J-channel or corner post to keep the partial panel from dropping.

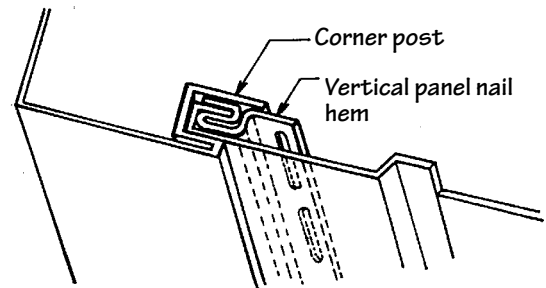

Figure 60.

- As an alternative, you can create a starter strip for vertical siding by cutting the nail hem and adjacent lock off a vertical siding panel. Fasten it inside the receiver channel of the corner post. Be sure this piece is plumb. Leave enough clearance in the pocket of the corner post to allow the siding panel to be attached (Fig. 60).

## Gable Ends

For application of vertical siding to gables, use the same method described above for a balanced appearance.

- Begin by fastening J-channel along the inside edge of the roof. Install an upward facing J-channel as a vertical base on top of the previously installed J-channel at the base of the gable, as shown in Fig. 58. As an alternative, install back-to-back J-channels, centered with the peak of the gable. Install a cut nailing hem as a starter-strip in each J-channel, as described above (Fig. 60).

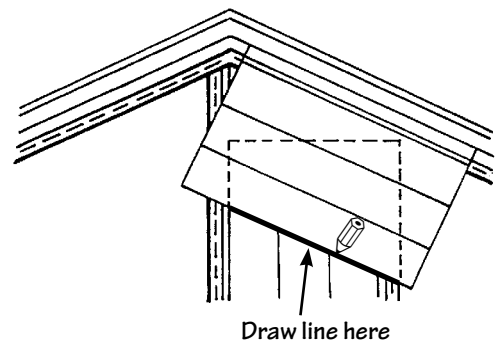

Figure 61.

- Make a pattern for end cuts along the gable using two pieces of scrap siding (Fig. 61). Lock one piece into the vertical strip at the center of the wall. Hold the edge of the other piece against and in line with the roof line. Mark the slope on the vertical piece and cut along that line. Use it as a pattern to mark and cut the ends of all other panels required for this side of the gable end. Make another pattern for the other side of the gable.

# SOFFIT INSTALLATION

Soffit is used to enclose the underside of an eave. The installation of soffit will determine the positioning of the inside and outside corner posts. It also is necessary to complete the soffit before the final course of siding is installed on the wall.

Vinyl soffit is designed to be easily installed lengthwise from wall to fascia. Soffit panels are similar to vertical siding. Manufacturers produce both solid and vented panels, as well as combinations of the two.

## Preparation

Inspect and plan the job in advance. For residing applications, nail down any loose panels, boards, or shingles. Check surfaces for straightness and fur when necessary. Surfaces should be uniform and straight from various viewing angles.

The procedure used to install soffit depends on the construction of the eave. There are two different types of eaves:

- Open eaves—eaves with exposed rafters or trusses—are typical of new construction. Open eave installation procedures are also used when removing damaged soffit during a residing project.
- Enclosed eaves—eaves with soffit in place—are typical of residing projects.

When transitioning soffit at the peak of a gable (Fig. 62), secure two J-channels back-to-back to receive an individual piece of soffit on each accessory.

## Installation Over Open Eaves

Follow this five-step procedure:

1. Install receiving channels (soffit receiver or J-channel).
  - There are several ways to install receiving channels for soffit. You can use accessories such as J-channel or F-channel. The best approach is to select a method that works most effectively with the construction techniques used to create the eave.
  - Examine the illustrations on the right side of page 33 and find one that most closely resembles the construction methods used on this particular project (Fig. 63 through 66).
  - Install the receiving channels following the details shown in the illustrations on page 33. Nail channels every 8" to 12" (203mm to 305mm), positioning the nail in the center of the slot. Do not nail tightly.

**NOTE: Ventilation Requirements:**  
Proper attic ventilation is important for any home. Consult the local building code for the appropriate requirements for a specific geographic area, and use vented soffit or other vented products as required.

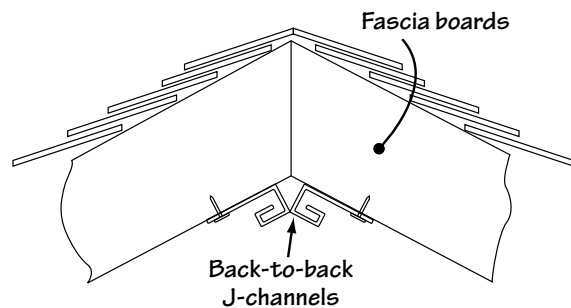

Figure 62.

**NOTE:** Nailing strips must be installed as shown in Fig. 66 if the eave span is greater than 16" (406mm), unless otherwise specified in the soffit manufacturer's instructions. In areas with high wind restrictions, nailing should not exceed 12" (305mm) on center, unless otherwise specified by the manufacturer.

- If no soffit receiver is available for a situation best suited for the product, the J-channel can be modified to create an F-receiver (Fig. 67).
- Simply cut slots in the nail flange area where it would be nailed to the wall (Fig. 67). After cutting the nail flange, bend the flange back and nail it to the wall.
- If the soffit will turn a corner, cut and install the channel so there is 1/4" (6.4mm) for expansion at each of the adjoining walls.

2. Measure from the wall to the fascia board. Then subtract 1/2" (12.7mm) to allow for expansion. Mark and cut this dimension on a soffit panel.

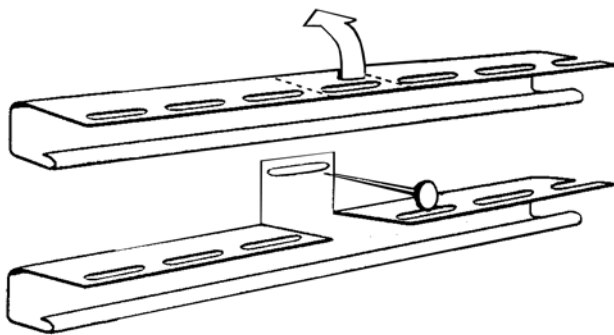

Figure 67.

**NOTE:** These illustrations are based on common installation practices used in most areas of North America. Local environmental conditions (particularly high wind zones) and building codes may call for different installation techniques. Always consult the manufacturer's installation instructions and local building codes to determine the correct installation methods to use on any job.

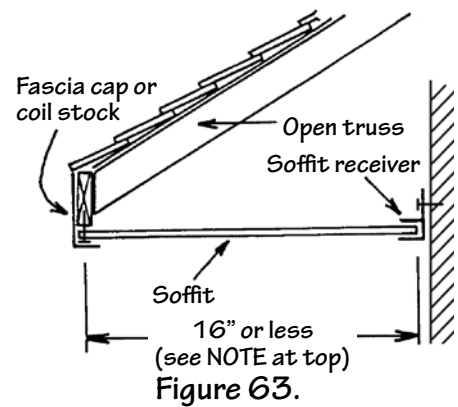

Figure 63.

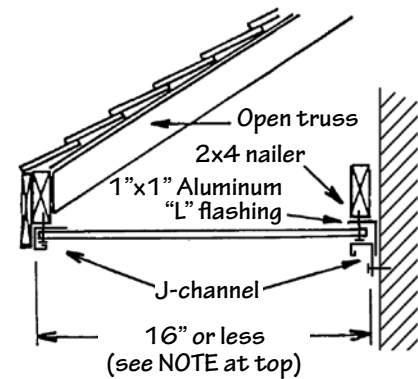

Figure 64.

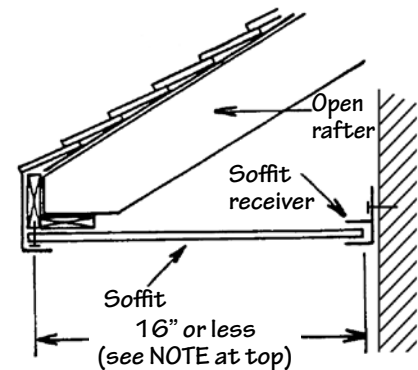

Figure 65.

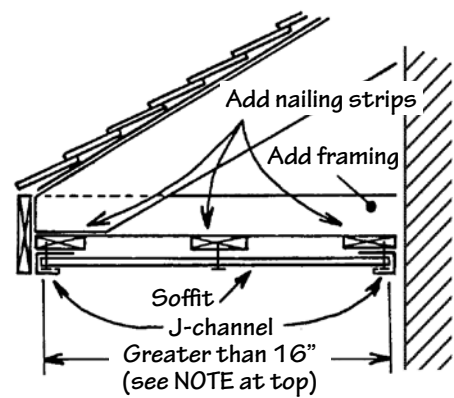

Figure 66.

3. Insert the panel into the channel on the wall, then into the channel at the fascia board (Fig. 68).

- It might be necessary to flex the panel slightly to insert it into the second channel.
- Make certain the panel is perpendicular to the wall, then nail. Depending on the installation method being used, nails will be hammered either into a nailing strip or a fascia board.
- When using a nailing strip, do not nail tightly—allow movement for expansion. Continue the installation by locking and nailing the panels. Make certain the panels are fully locked along their entire length.

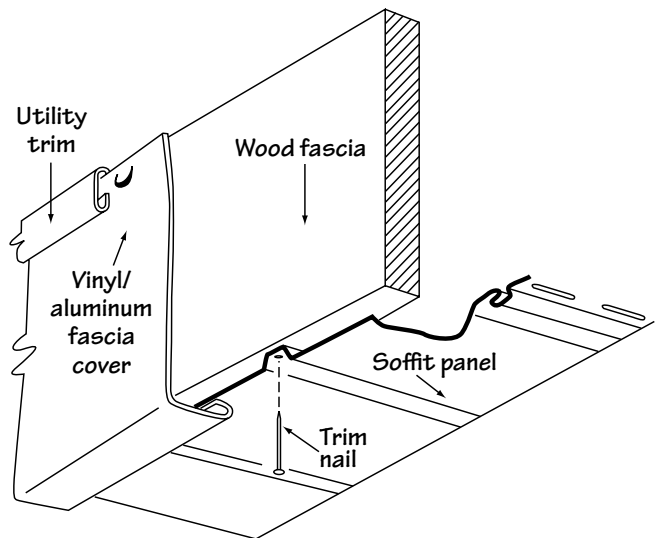

Figure 68.

4. To turn a corner, measure from the channel at the wall corner to the channel at the corner of the fascia board (Fig. 69). Subtract 1/4" (6.4mm) for expansion. Cut and install soffit double channel lineal or back-to-back J-channel. If necessary, install nailing strips to provide backing for the lineal. Miter cut the corner soffit panels and install as described in Step 3.

5. To complete the installation, apply the utility trim and fasten the aluminum fascia cap or formed aluminum coil stock with painted trim nails. If necessary to face nail fascia, drill holes for the trim nails to allow for expansion and to reduce denting of the aluminum.

**NOTE:** When nailing to the fascia board, use trim nails. Drive the nail through the nail flange and "V"-shaped groove within the soffit panel (Fig. 68). This is one of the rare instances that face-nailing is permissible. Once a soffit panel is face-nailed, it will expand only in one direction, in this case, toward the receiving channel. Be sure to leave space for the full expansion allowance in the receiving channel.

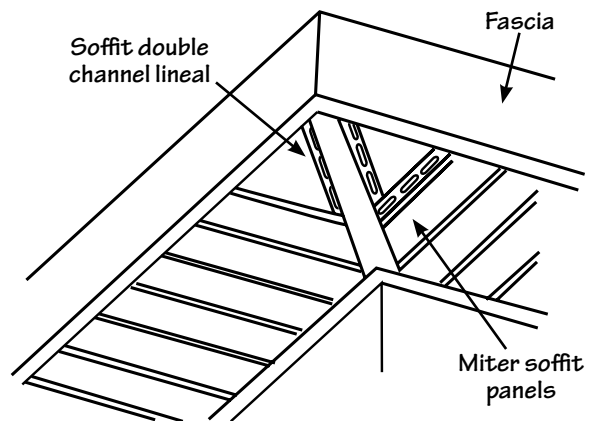

Figure 69.

## Installation Over Enclosed Eaves

The procedure used to install soffit over an enclosed eave in a remodeling project is almost identical to that used for an open eave in new construction. The major difference is the installation of the J-channel (Fig. 70 and 71).

- Determine the preferred method of installing soffit at the fascia board.
- When installing J-channel at either wall of fascia board, nail every 8" to 12" (203mm to 305mm).
- If the soffit is to turn a corner, cut and install J-channel to allow 1/4" (6.4mm) for expansion at each of the adjoining walls and fascia boards.
- When installing vented soffit panels, if the existing soffit doesn't have openings for ventilation, cut an adequate number of openings.
- To complete the installation, follow Steps 3 through 5 from "Installation Over Open Eaves" on page 34.

**NOTE:** If the existing soffit is rotted or damaged, remove it completely before installing vinyl soffit, then use the instructions for open eaves.

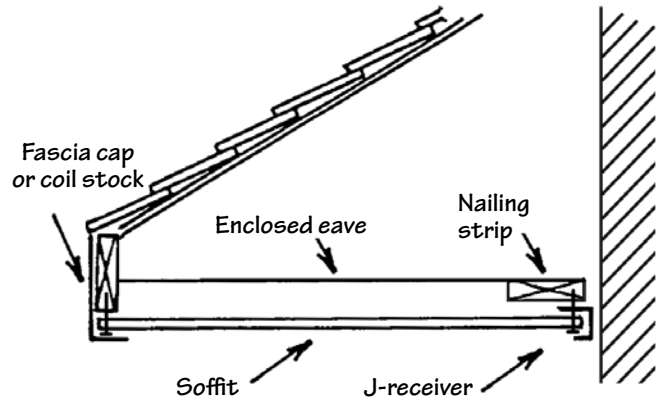

Figure 70.

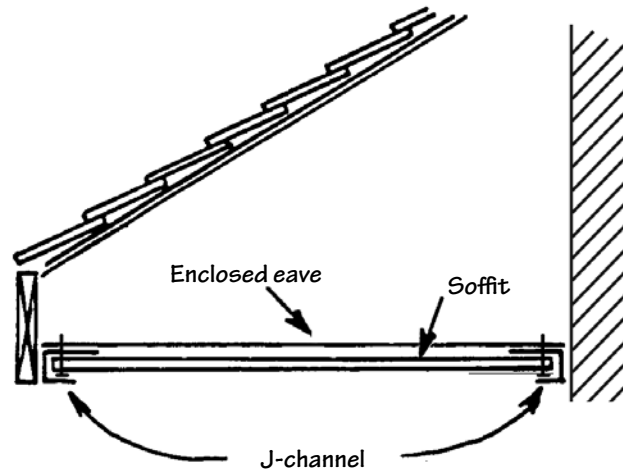

Figure 71.

## Porch Ceilings

The procedures used to install a porch ceiling are in many ways similar to those used to install soffit. These procedures vary slightly, depending on whether the installation is a new construction or a residing project.

### New Construction Projects

1. Begin by installing receiving channels on all four sides of the porch (Fig. 72). If F-channels are being used, nail them to the existing walls. If J-channels are being used, a nailing base will have to be installed.
2. When using light blocks to attach external light fixtures, install them to adequate backing.
3. Plan the layout of the ceiling panels to achieve an even balance or to align with adjacent work. If the ceiling panels will run parallel to the ceiling joists, additional 1" x 3" (25.4mm x 76.2mm) wood furring nailing strips will have to be installed. Install these nailing strips perpendicular to the ceiling joists, placing a strip every 8" to 12" (203mm to 305mm).
4. Invert the J-channels and nail them to the underside of the wood strips along the perimeter of the ceiling area.
5. Install the first panel into the channels at one end of the porch. Be sure to leave room for expansion. Nail every 8" to 12" (203mm to 305mm), positioning nails in the centers of slots. Do not nail tightly. Install the remaining panels. When cutting the last panel of the first course, be sure to allow room for expansion.
6. For areas where more than one panel length is needed, use a double channel lineal or back-to-back J-channel.
7. If it is necessary to cut the nailing hem off the final panel, use a snap lock punch to create tabs every 6" (152mm) along the cut edge. Attach utility trim and insert the panel into the receiving channel.

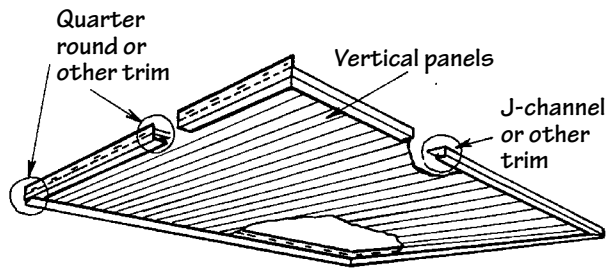

Figure 72.

### Residing Projects

1. Check to be sure the existing ceiling can serve as a solid nailing base.
2. If the existing ceiling is solid, remove all existing moldings and fixtures from the ceiling and begin by nailing inverted J-channels along the perimeter of the ceiling area. Then follow Steps 2 through 6 in the instructions under "New Construction Projects." With a solid ceiling, however, additional nailing strips are not necessary. Use the existing ceiling as the nailing base for the panels.
3. If the existing ceiling is not solid, install nailing strips to provide a secure nailing base, then install the J-channels. Additional nailing strips should be installed if the ceiling panels are to run parallel to the ceiling joists. Follow the instructions in Steps 2 through 6 for new construction.

## OTHER RECOMMENDATIONS

### Attaching Shutters

To install shutters around windows:

- Pre-drill holes through the shutters for attachment screws and mark the location of these holes on the siding (Fig. 73).
- Using the hole marks as a guide, drill expansion holes through the siding where attachment screws will be located, a minimum 1/4" (6.4mm) larger than the diameter of the screw (Fig. 74).
- When attaching the shutters, do not fasten such that the shutter is tight against the siding, otherwise expansion of the siding will be restricted.

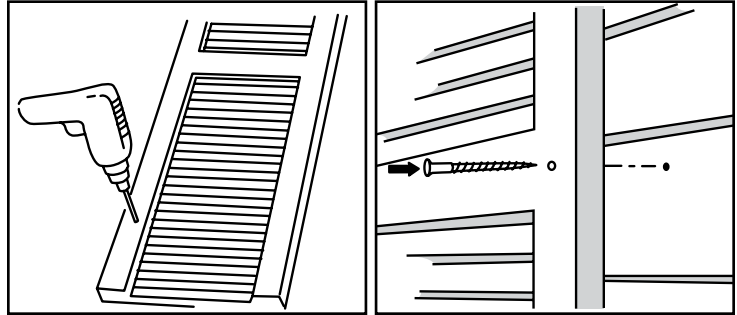

Figure 73.

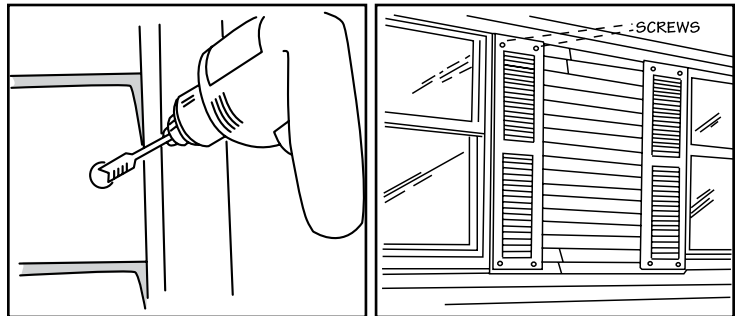

Figure 74.

### Replacing a Damaged Panel

To remove a panel for any reason:

- Slip the zip lock or unlocking tool behind the bottom of the panel above the one to be replaced and unzip it from the lock on the damaged panel (Fig. 75).
- Gently bend out the upper panel. Take the nails out of the damaged panel and remove it (Fig. 76).
- Lock on the new panel and nail it up (Fig. 77).
- Use the unlocking tool again to zip the upper panel over the lock on the new panel (Fig. 78).

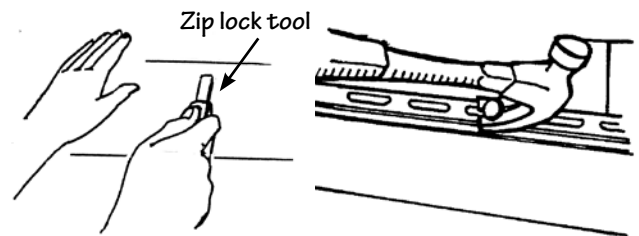

Figure 75.

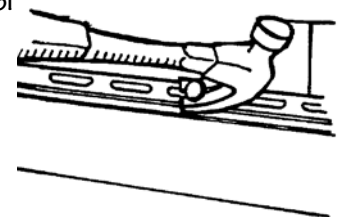

Figure 76.

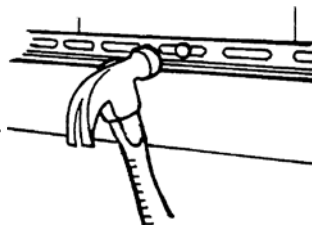

Figure 77.

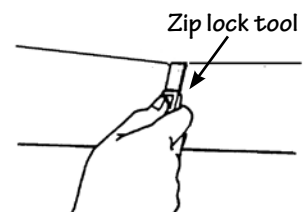

Figure 78.

## Capping a Corner Post

- Corner posts on homes with a second-story overhang need to be capped by making the cuts shown (Fig. 79). Fold the flaps created over each other as indicated.
- Drill a 1/8" (3.2mm) hole in the center, through both layers of vinyl, and install a pop rivet to hold them in place. Cut a notch in both layers to allow clearance for the corner (Fig. 80).

## Repairing a Damaged Corner Post

Repair a damaged corner post with a series of cuts:

- Cut away the face of the damaged corner, leaving the nail hem intact.
- Remove the nail hem from the replacement corner and trim it to fit.
- Place the new corner over the nailing hem of the old one and fasten it into position.

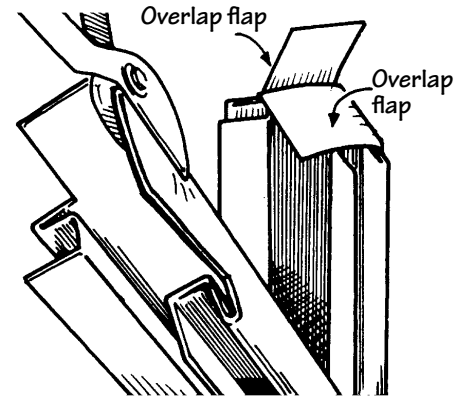

Figure 79.

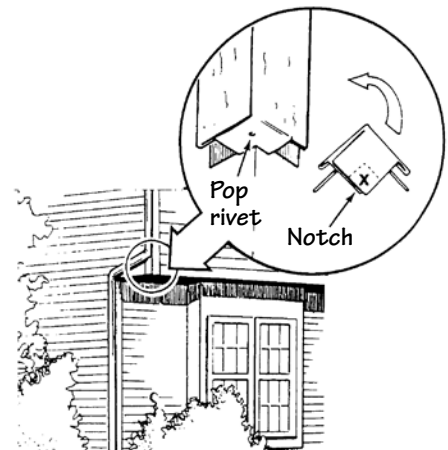

Figure 80.





VINYL SIDING INSTITUTE



National Housing Center  
1201 15th Street NW  
Suite 220  
Washington, DC 20005

For more information,  
visit VSI's website  
[www.vinylsiding.org](http://www.vinylsiding.org)